

Kramer Electronics, Ltd.



USER MANUAL

Model:

F-121

*XGA / Audio Line Transmitter Mounting Box
for Ackermann Floor Boxes*

Contents

1	Introduction	1
2	Getting Started	1
3	Overview	2
3.1	About the Power Connect Feature	3
3.2	Shielded Twisted Pair (STP) / Unshielded Twisted Pair (UTP)	3
3.3	DDC Support	4
3.4	Defining EDID	4
3.5	Achieving the Best Performance	4
4	Your F-121 XGA / Audio Line Transmitter Mounting Box	5
5	Installing the F-121	6
5.1	Installing a Kramer Insert	6
5.2	Connecting the Cables to the Rear Side of the F-121	6
5.3	Installing the F-121 inside the Ackermann Floor Box	7
5.4	Connecting the Front Panel Ports	8
5.5	Wiring the 8-pin Terminal Block Line Output Connector	8
5.6	Wiring the CAT 5 LINE IN / LINE OUT RJ-45 Connectors	9
6	Technical Specifications	10

Figures

Figure 1:	The F-121 XGA / Audio Line Driver Mounting Box	2
Figure 2:	F-121 Fitted in an Ackermann Floor Box	3
Figure 3:	F-121 XGA Line Transmitter Mounting Box	5
Figure 4:	Installing the F-121 XGA / Audio Line Transmitter Mounting Box	7
Figure 5:	Terminal Block Pinouts	8
Figure 6:	CAT 5 PINOUT	9

Tables

Table 1:	F-121 Features	5
Table 2:	CAT 5 PINOUT	9
Table 3:	Technical Specifications of the F-121	10

1 Introduction

Welcome to Kramer Electronics! Since 1981, Kramer Electronics has been providing a world of unique, creative, and affordable solutions to the vast range of problems that confront the video, audio, presentation, and broadcasting professional on a daily basis. In recent years, we have redesigned and upgraded most of our line, making the best even better! Our 1,000-plus different models now appear in 11 groups¹ that are clearly defined by function.

Thank you for purchasing the Kramer **F-121 XGA / Audio Line Transmitter Mounting Box** for Ackermann floor boxes, which is ideal for:

- Presentation venues
- Multimedia applications
- Long range graphics distribution for schools, hospitals, security, and stores

The **F-121** includes two single Kramer inserts² (covered with blank inserts) and is mounted into Ackermann flush floor service units that accept GB2 and GB3 size boxes³.

The package includes the following items:

- **F-121**
- Power adapter (12V DC Input) and this user manual⁴

2 Getting Started

We recommend that you:

- Unpack the equipment carefully and save the original box and packaging materials for possible future shipment
- Review the contents of this user manual
- Use Kramer high-performance high-resolution cables⁵

1 GROUP 1: Distribution Amplifiers; GROUP 2: Switchers and Matrix Switchers; GROUP 3: Control Systems; GROUP 4: Format/Standards Converters; GROUP 5: Range Extenders and Repeaters; GROUP 6: Specialty AV Products; GROUP 7: Scan Converters and Scalers; GROUP 8: Cables and Connectors; GROUP 9: Room Connectivity; GROUP 10: Accessories and Rack Adapters; GROUP 11: Sierra Products

2 The complete list of Kramer products can be found on our Web site at <http://www.kramerelectronics.com>

3 GB2 and GB3 are Ackermann mounting boxes that fit into Ackermann floor boxes

4 Download up-to-date Kramer user manuals from the Internet at <http://www.kramerelectronics.com>

5 The complete list of Kramer cables is on our Web site at <http://www.kramerelectronics.com>

3 Overview

The **F-121** mounting box for Ackermann floor boxes is a twisted pair transmitter for computer graphics video signals up to and exceeding UXGA and unbalanced stereo audio. It converts the input signals into a twisted pair signal that it transmits to a compatible twisted pair receiver¹. The **F-121** includes two adjacent openings² for Kramer inserts.

In particular, the **F-121** transmitter has:

- A transmission range of more than 300ft (more than 100m), and a 20kHz audio bandwidth with an S/N ratio that exceeds 80dB on the same transmission range
- The capability to store EDID when programmed by the Kramer **FC-200 XGA EDID Copier**³
- A resolution of up to UXGA
- The Kramer Power Connect™ feature
- A 12V DC power supply

[Figure 1](#) shows the **F-121 XGA / Audio Line Transmitter Mounting Box**:



Figure 1: The F-121 XGA / Audio Line Driver Mounting Box

1 For example, the Kramer TP-122

2 Lets you fit two single inserts or one dual insert

3 The EDID of the display on the transmitter can be captured via the FC-200

[Figure 2](#) shows the **F-121** fitted in an Ackermann floor box:



Figure 2: F-121 Fitted in an Ackermann Floor Box

3.1 About the Power Connect Feature

The Power Connect feature applies as long as the cable can carry power. The distance does not exceed 50m on standard CAT 5 cable, for longer distances, heavy gauge cable should be used¹.

For a CAT 5 cable exceeding a distance of 50m, separate power supplies should be connected to the transmitter and to the receiver simultaneously.

3.2 Shielded Twisted Pair (STP) / Unshielded Twisted Pair (UTP)

We recommend that you use Shielded Twisted Pair (STP) cable. There are different levels of STP cable available, and we advise you to use the best quality STP cable that you can afford. Our non-skew-free cable, Kramer **BC-STP** is intended for analog signals where skewing is not an issue. For cases where there is skewing, our UTP skew-free cable, Kramer **BC-XTP**, may be used. Bear in mind, though, that we advise using STP cables where possible, since the compliance to electromagnetic interference was tested using those cables.

¹ CAT 5 cable is still suitable for the video/audio transmission, but not for feeding the power at these distances

Although Unshielded Twisted Pair (UTP) cable might be preferred for long range applications, the UTP cable should be installed far away from electric cables, motors and so on, which are prone to create electrical interference. However, since the use of UTP cable might cause inconformity to electromagnetic standards, Kramer does not commit to meeting the standard with UTP cable.

3.3 DDC Support

When establishing a VGA connection between a PC or laptop and a display device, a set of parameters known as EDID is exchanged between them, which is carried over the DDC channel (PINs 12 and 15). In some PC graphic cards and laptops, this information exchange is essential for proper VGA OUT operation.

3.4 Defining EDID

The Extended Display Identification Data (EDID¹) is a data-structure, provided by a display, to describe its capabilities to a graphics card (that is connected to the display's source). The EDID enables the PC or laptop to "know" what kind of monitor is connected to the output. The EDID includes the manufacturer's name, the product type, the timing data supported by the display, the display size, luminance data and (for digital displays only) the pixel mapping data.

3.5 Achieving the Best Performance

To achieve the best performance:

- Use only good quality connection cables² to avoid interference, deterioration in signal quality due to poor matching, and elevated noise levels (often associated with low-quality cables)
- Avoid interference from neighboring electrical appliances that may adversely influence signal quality and position your Kramer **F-121** away from moisture, excessive sunlight and dust

	Caution: No operator serviceable parts inside unit
	Warning: Use only the Kramer Electronics input power wall adapter that is provided with the unit
	Warning: Disconnect power and unplug unit from wall before installing or removing the device or servicing unit

¹ Defined by a standard published by the Video Electronics Standards Association (VESA)

² Available from Kramer Electronics on our Web site at <http://www.kramerelectronics.com>

4 Your F-121 XGA / Audio Line Transmitter Mounting Box

[Figure 3](#) and [Table 1](#) define the F-121:

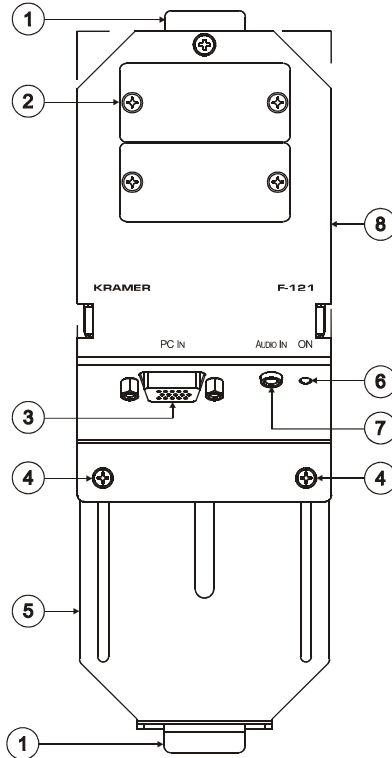

Figure 3: F-121 XGA Line Transmitter Mounting Box

Table 1: F-121 Features

#	Feature	Function
1	Mounting Tabs	For fitting the F-121 into an Ackermann floor box
2	Blank Inserts (2)	Replace with Kramer wall plate inserts (see section 5.1)
3	PC IN 15-pin HD F Connector	Connect to the XGA source
4	Slide Screws (2)	Release to increase or decrease the length of the unit; tighten to fix size
5	Adjustable Mounting Slide	For adjusting the size of the unit to fit an Ackermann floor box
6	ON LED	Lights red when receiving power, lights green when receiving a signal from a video source
7	AUDIO IN 3.5mm mini Connector	Connect to an unbalanced stereo audio source
8	8-pin Terminal Block Line Output Connector ¹	Connect to the line in connector on the receiver (see section 5.5)

¹ Located inside the mounting box

5 Installing the F-121

To install the **F-121** you have to install the inserts and the transmitter which is connected via TP to a receiver.

To install the **F-121**, do the following:

- Install the Kramer inserts (see section [5.1](#))
- Connect the cables to the rear side (see section [5.2](#))
- Install the **F-121** inside the Ackermann floor box (see section [5.3](#))
- Connect the front panel ports (see section [5.4](#))
- Connect the twisted pair cable to the receiver (for example, the Kramer **TP-122**)

5.1 Installing a Kramer Insert

To install a Kramer insert, do the following:

1. Unscrew the two screws holding the blank insert and remove it.
2. Place and align the required wall plate insert item over the opening.
3. Insert the two screws to fix the insert in place, and tighten them.

5.2 Connecting the Cables to the Rear Side of the F-121

To connect the rear side cables, do the following:

1. Run the cables through the Ackermann underfloor cable opening.
2. Connect the cables to the rear side of the inserts.
3. Connect the cables to the rear side of the **F-121** transmitter, that is, attach the:
 - Terminal block line output of the **F-121** to the pre-installed UTP wiring that connects to the TP receiver¹ (with a range of more than 300ft (>100m)), see section [5.5](#)
 - 12V DC power supply to the power terminal blocks (connect the wire labeled “+” to the +12V pin, and the wire labeled “-” to the GND pin) taking care that the polarity is correct (see [Figure 5](#))

¹ For example, the Kramer TP-122 XGA / Audio Line Receiver

5.3 Installing the F-121 inside the Ackermann Floor Box

To install the **F-121** inside the Ackermann floor box, as illustrated in [Figure 4](#), perform the following steps:

1. Slightly release the two slide screws (do not remove them) to let the adjustable mounting slide move freely.
2. Fit the **F-121** mounting box into its designated place inside the Ackermann floor box (see [Figure 2](#)).
3. Insert the fixed tab into the slot in the Ackermann box.
4. Adjust the size of the unit to fit the space in the box.
5. Insert the tab on the adjustable mounting box to the appropriate slot in the Ackermann box.
6. Tighten slide screws to fix the size of the unit.

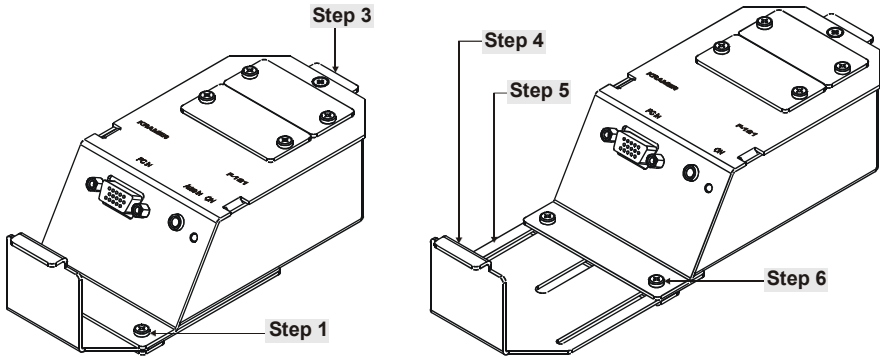

Figure 4: Installing the F-121 XGA / Audio Line Transmitter Mounting Box

5.4 Connecting the Front Panel Ports

To connect the front panel ports:

1. On the **F-121** transmitter section, connect:
 - The XGA source (for example, a laptop's graphics card) to the PC IN 15-pin HD (F) connector
 - An audio source to the AUDIO IN 3.5mm mini jack, for example, using a Kramer C-GMA/GMA cable (VGA 15-pin HD (M) +Audio jack to VGA 15-pin HD (M) +Audio jack)^{1,2}
2. Connect the appropriate connectors to the inserts.

5.5 Wiring the 8-pin Terminal Block Line Output Connector

The 8-pin terminal block is an easy plug-in connector for attaching the UTP cable. Follow the colors of the color-coded sticker on these terminals for proper connection of the UTP cable. [Figure 5](#) defines the pinouts for the terminal block.

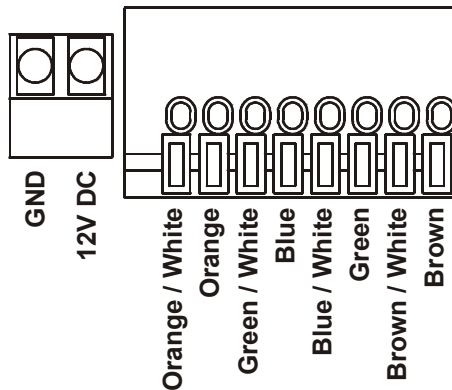

Figure 5: Terminal Block Pinouts

Notes:

- Use the connector clips only when removing wires, not when inserting them
- Each wire should protrude 9mm (0.35") from the plastic insulation so that it can be easily connected. To prevent the wires crossing, be sure that each wire is fully inserted

¹ Not supplied. The complete list of Kramer cables is on our Web site at <http://www.kramerelectronics.com>

² Alternatively, you can connect an XGA source to the XGA INPUT 15-pin HD (F) connector, and a separate audio source to the AUDIO IN 3.5mm mini jack

5.6 Wiring the CAT 5 LINE IN / LINE OUT RJ-45 Connectors

[Table 2](#) and [Figure 6](#) define the UTP CAT 5 PINOUT, on the RJ-45 connector:

Table 2: CAT 5 PINOUT

EIA /TIA 568A		EIA /TIA 568B	
PIN	Wire Color	PIN	Wire Color
1	Green / White	1	Orange / White
2	Green	2	Orange
3	Orange / White	3	Green / White
4	Blue	4	Blue
5	Blue / White	5	Blue / White
6	Orange	6	Green
7	Brown / White	7	Brown / White
8	Brown	8	Brown
Pair 1		Pair 1	
Pair 2		Pair 2	
Pair 3		Pair 3	
Pair 4		Pair 4	

Figure 6: CAT 5 PINOUT

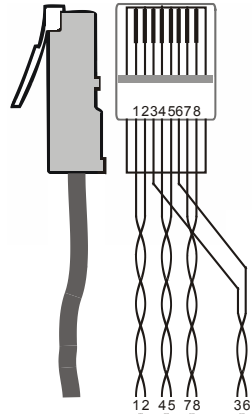

6 Technical Specifications

[Table 3](#) lists the technical specifications:

Table 3: Technical Specifications¹ of the F-121

INPUTS:	1 UXGA on a 15-pin HD (F) connector 1 Unbalanced stereo audio on a 3.5mm mini connector 1 Power 12V DC on 2-pin terminal block	
OUTPUTS:	1 UTP on an 8-pin terminal block with springs	
MAX. OUTPUT LEVEL:	Video: 1.9Vpp	Audio: 2.7Vpp
RESOLUTION:	Up to UXGA	
AUDIO BANDWIDTH:	20kHz	
DIFF. GAIN:	5.8%	
DIFF. PHASE:	0.5 Deg	
K-FACTOR:	<0.05%	
S/N RATIO:	Video: 60dB @5MHz	Audio: 78dB @ 1KHz
CONTROLS:	Video detection LED	
COUPLING:	Video: AC	Audio: AC
AUDIO THD + NOISE:	0.04%	
AUDIO 2 nd HARMONIC:	0.001%	
POWER SOURCE:	12V DC 340mA (feeding TP-122-od receiver); self current 110mA	
DIMENSIONS:	Closed: 7.5cm x 15.7cm x 4.4cm (2.95" x 6.18" x 1.73") W, D, H Open: 7.5cm x 15.7cm x 4.4cm (2.95" x 6.18" x 1.73") W, D, H	
WEIGHT:	0.19kg (0.42lbs) approx.	
ACCESSORIES:	Power supply	

¹ Specifications are subject to change without notice

LIMITED WARRANTY

We warrant this product free from defects in material and workmanship under the following terms.

HOW LONG IS THE WARRANTY

Labor and parts are warranted for seven years from the date of the first customer purchase.

WHO IS PROTECTED?

Only the first purchase customer may enforce this warranty.

WHAT IS COVERED AND WHAT IS NOT COVERED

Except as below, this warranty covers all defects in material or workmanship in this product. The following are not covered by the warranty:

1. Any product which is not distributed by us or which is not purchased from an authorized Kramer dealer. If you are uncertain as to whether a dealer is authorized, please contact Kramer at one of the agents listed in the Web site www.kramerelectronics.com.
2. Any product, on which the serial number has been defaced, modified or removed, or on which the WARRANTY VOID IF TAMPERED sticker has been torn, reattached, removed or otherwise interfered with.
3. Damage, deterioration or malfunction resulting from:
 - i) Accident, misuse, abuse, neglect, fire, water, lightning or other acts of nature
 - ii) Product modification, or failure to follow instructions supplied with the product
 - iii) Repair or attempted repair by anyone not authorized by Kramer
 - iv) Any shipment of the product (claims must be presented to the carrier)
 - v) Removal or installation of the product
 - vi) Any other cause, which does not relate to a product defect
 - vii) Cartons, equipment enclosures, cables or accessories used in conjunction with the product

WHAT WE WILL PAY FOR AND WHAT WE WILL NOT PAY FOR

We will pay labor and material expenses for covered items. We will not pay for the following:

1. Removal or installations charges.
2. Costs of initial technical adjustments (set-up), including adjustment of user controls or programming. These costs are the responsibility of the Kramer dealer from whom the product was purchased.
3. Shipping charges.

HOW YOU CAN GET WARRANTY SERVICE

1. To obtain service on your product, you must take or ship it prepaid to any authorized Kramer service center.
2. Whenever warranty service is required, the original dated invoice (or a copy) must be presented as proof of warranty coverage, and should be included in any shipment of the product. Please also include in any mailing a contact name, company, address, and a description of the problem(s).
3. For the name of the nearest Kramer authorized service center, consult your authorized dealer.

LIMITATION OF IMPLIED WARRANTIES

All implied warranties, including warranties of merchantability and fitness for a particular purpose, are limited in duration to the length of this warranty.

EXCLUSION OF DAMAGES

The liability of Kramer for any effective products is limited to the repair or replacement of the product at our option. Kramer shall not be liable for:

1. Damage to other property caused by defects in this product, damages based upon inconvenience, loss of use of the product, loss of time, commercial loss; or
2. Any other damages, whether incidental, consequential or otherwise. Some countries may not allow limitations on how long an implied warranty lasts and/or do not allow the exclusion or limitation of incidental or consequential damages, so the above limitations and exclusions may not apply to you.

This warranty gives you specific legal rights, and you may also have other rights, which vary from place to place.

NOTE: All products returned to Kramer for service must have prior approval. This may be obtained from your dealer.

This equipment has been tested to determine compliance with the requirements of:

- EN-50081: "Electromagnetic compatibility (EMC); generic emission standard.
Part 1: Residential, commercial and light industry"
- EN-50082: "Electromagnetic compatibility (EMC) generic immunity standard.
Part 1: Residential, commercial and light industry environment".
- CFR-47: FCC* Rules and Regulations:
Part 15: "Radio frequency devices
Subpart B Unintentional radiators"

CAUTION!

- Servicing the machines can only be done by an authorized Kramer technician. Any user who makes changes or modifications to the unit without the expressed approval of the manufacturer will void user authority to operate the equipment.
- Please use recommended interconnection cables to connect the machine to other components.
* FCC and CE approved using STP cable (for twisted pair products)



For the latest information on our products and a list of Kramer distributors, visit our Web site: www.kramerelectronics.com where updates to this user manual may be found. We welcome your questions, comments and feedback.



Caution

Safety Warning:

Disconnect the unit from the power supply before opening/servicing.



Kramer Electronics, Ltd.

Web site: www.kramerelectronics.com

E-mail: info@kramerel.com

P/N: 2900-000715 REV 1