

EH1020

DLP® Projector

Make an impact

- Full HD 1080p for detail and clarity
- Bright projection – 3000 ANSI Lumens
- Digital connectivity, HDMI – perfect Full HD display
- Low ownership costs – up to 4000hrs lamp life
- 8W speaker – all-in-one multimedia set-up
- Rapid power on and shutdown – saving you time & money
- Portable – carry bag provided for easy transportation
- Environmentally friendly design <1W standby mode
- Optoma EH1020 filter-free design – virtually no maintenance

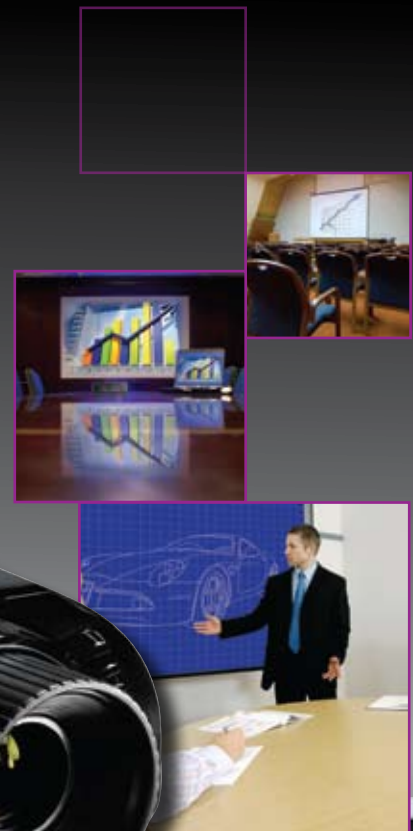

Full HD
1080p

Powerful Full 1080p Projector

Full HD, native resolution for applications where you want to make an impact. The EH1020 produces crystal-clear full HD images, perfect for projection for a broad range of applications including technical, advertising media and medical uses where detail matters. Installed or on the move, the versatile EH1020 incorporates extensive connectivity and powerful 8W speakers.

The environmentally friendly EH1020 has energy saving features including <1W standby mode and auto power off saving you both time and money. Our unique Optoma Colour and Imager guarantees ensure hassle-free, long-lasting projection.

FULL HD

Full HD (1920 x 1080) has twice the resolution of standard HD. EH1020 is compatible with HDTV broadcasts and high-definition DVDs to project impressive full 1080p images and video in their original digital brilliance.



XGA (1024 x 768)

1080p (1920 x 1080)



RESOLUTION COMPARISON

Projector Resolution	PC Compatibility				Video Compatibility	
	XGA 1024 x 768	WXGA 1280 x 800	SXGA 1280 x 1024	SXGA+ 1400 x 1050	HD Ready (720p)	Full HD (1080p)
XGA	1024 x 768	✓	-	-	-	-
720p	1280 x 720	-	-	-	✓	-
WXGA	1280 x 800	✓	✓	-	✓	-
1080p	1920 x 1080	✓	✓	✓	✓	✓

CONTROL

The extensive RS232 command set makes it simple and easy to control the EH1020 with any control system.

AMX Compatibility – Dynamic Discovery

Protocol is incorporated into the EH1020. This feature allows for easy installation with AMX control systems.



STUNNING IMAGE QUALITY

Full HD 1080p technology delivers impeccable image quality associated with the best digital cinema performance around the world. Digital HDMI or DVI signal creates a true digital projection system that produces a spectacular High Definition display. This unprecedented combination ensures natural, life-like images with crystal clarity.

XGA Resolution

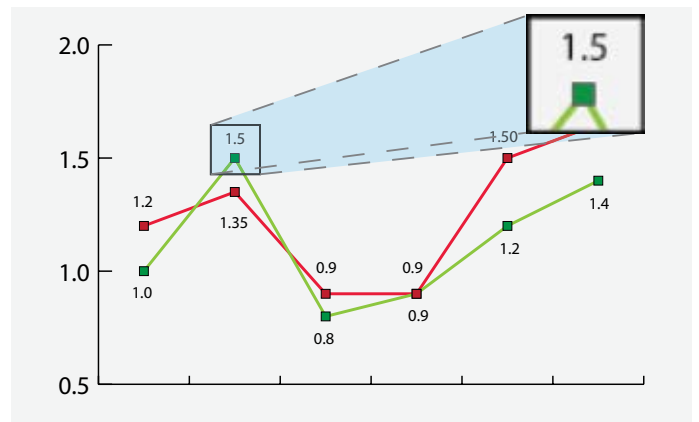

1080p Resolution

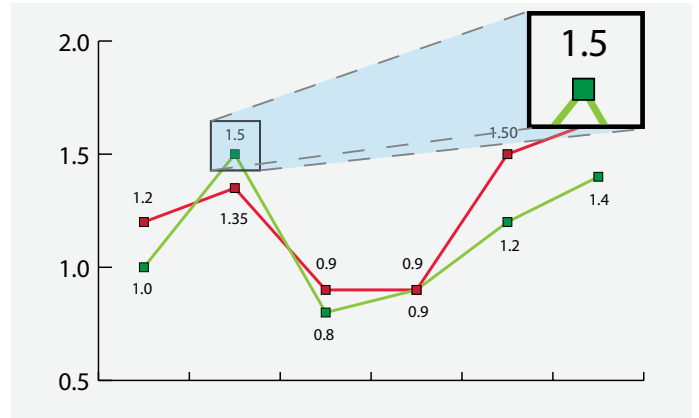

EXTENSIVE CONNECTIVITY

This native 1080p projector accepts a wide variety of computer and video input signals.

Connectivity includes: HDMI, VGA (SCART/ Component via adaptor), S-Video, Composite, VGA-Out, RS232 and +12V trigger.

Two audio inputs for individual PC and video connections enable the EH1020 to function as an audio switcher and volume controller, thereby eliminating complicated and costly additional audio hardware and cabling.

AUDIO CAPABILITY

Built-in 8W speaker offers excellent audio support. The EH1020 is easy to set up without the need for costly external speakers.

AMAZING COLOURS

The EH1020 incorporates BrilliantColor™ technology to produce stunningly bright images with perfectly balanced life-like colours.

COLOUR AND IMAGER GUARANTEE

Bright colours and fantastic image quality are guaranteed for an amazing 5 years* after purchase - giving piece of mind that the technology inside the Optoma EH1020 projector won't fade or degrade.



VIRTUALLY MAINTENANCE FREE = LOWER COST OF OWNERSHIP

EH1020 provides lower cost of ownership, longer life and improved reliability. The filter-free projector design does not require regular filter cleaning or filter replacement, saving you time and money.



ENVIROMENTALLY FRIENDLY

The EH1020 incorporates energy saving features to conserve power and extend the lamp life:



To achieve the maximum 4000hrs** lamp life time the projector should be operating in STD mode and the shut down timer should be enabled to automatically switch off the projector if it is accidentally left on when no longer required. Enabling the <1W Standby mode will ensure the minimum energy consumption when the projector is not being used.



It takes less than 10 seconds for the projector to power up and shutdown, saving both time and energy.

FEATURES

- 6 preset display modes
- Security bar and password protection for added security
- Easy to use remote with laser pointer, mouse control and direct source selecting
- Direct power on
- Customised start-up logo
- +12v Trigger - electric screen control

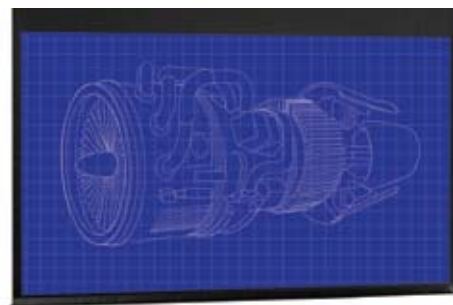

EH1020 SPECIFICATIONS

EH1020	
Native Resolution	1080p 1920 x 1080
Brightness - BRIGHT mode	3000 ANSI Lumens
Contrast	2200:1
Noise Level	28dB
Display Technology	Single 0.65" 1080p DC2 DMD chip DLP® Technology by Texas Instruments
Throw Ratio	1.5 - 1.8:1 (Projection Distance:Image Width)
Projection Distance	1.2 - 12m
Projection Lens	F/2.55~2.87; f=22.41~26.82mm, 1.2x Manual Zoom
Image Size	0.77 - 9.19m (30.15" - 361.75") Diagonal 16:9
Offset	116%
Weight / Dimensions (W x D x H)	2.9 kg / 324 x 234 x 97mm
Lamp Life**	4000/3000 (STD/BRIGHT mode)
Remote Control	Full function remote with laser pointer and direct source selecting
INPUTS	HDMI (HDCP) - audio supported 15 Pin D-Sub VGA (SCART/Component via adaptor) S-Video 4 Pin Mini Din Composite RCA 3.5mm Audio Mini Jack - Audio computer inputs Stereo RCA - Audio video inputs USB (remote mouse)
CONTROL	RS232 - 3 Pin Mini DIN
OUTPUT	15 Pin D-Sub VGA Stereo Audio Mini Jack +12v Trigger
Audio	8W Speaker
Aspect Ratio	16:9 Native, 16:10/4:3 Compatible
Keystone Correction	± 20° Vertical
On Screen Display	19 Languages: English, German, French, Italian, Spanish, Portuguese, Polish, Dutch, Russian, Finnish, Swedish, Greek, Norwegian, Danish, Hungarian, Czech, Turkish, Farsi & Arabic
Compatible Resolutions	UXGA, SXGA+, HD, WXGA, XGA, SVGA
Video Compatibility	PAL SECAM 576i/p, NTSC 480i/p, HD 720p/1080i/1080p
Uniformity	85%
Displayable Colours	1.07 Billion
Horizontal Scan Rate	15 - 91kHz
Vertical Scan Rate	25 - 85Hz
Power Supply	100 - 240V, 50 - 60Hz
Power Consumption	308W BRIGHT mode < 1W Standby mode 256W STD mode < 1W Standby mode*
Operating Conditions	Operating: 5 - 40°C, 85% Humidity (Max), 3000m Altitude (Max)
Security	Security Bar, Kensington Lock Port, Password Protection
Standard Accessories	Soft Carry Bag, Lens Cover, AC Power Cord, VGA Cable, Full Function Remote, Batteries x 2, Quick Start Guide, CD User Manual, Warranty Card, WEEE Card
RoHS	Compliant
Lamp Warranty	6 months or 1000 hours - whichever comes sooner
Warranty	Warranty may vary by country. Please see www.optomaeurope.com or ask your local supplier for details
Colour Guarantee*	5 Years
Imager Guarantee***	5 Years

EASY TO USE REMOTE CONTROL

EH1020 Remote Control

- 1 Laser
- 2 Remote Mouse
- 3 Page Up/Down Control
- 4 Help/Enter
- 5 Vertical Keystone Correction
- 6 Volume Control
- 7 Brightness Adjustment
- 8 AV Mute
- 9 Direct Input Source Selection



EH1020 Connections

- 10 USB (Remote Mouse)
- 11 VGA OUT
- 12 VGA - SCART & Component
- 13 HDMI (audio supported)
- 14 S-Video
- 15 Composite Video
- 16 Audio Out
- 17 RS232
- 18 +12v Trigger
- 19 Audio In (VGA)
- 20 Audio In L & R (S-Video & Composite)
- 21 Kensington™ Lock
- 22 Security Bar

Exceptional Connectivity/Multiple Terminals



Easy to use remote with buttons to change the input sources



EH1020 Projection Distance 1.2 - 12m (16:9 Aspect Ratio)							
Projection Distance (m)	Max. Horizontal Image Size (m)	Min. Horizontal Image Size (m)	Max. Vertical Image Size (m)	Min. Vertical Image Size (m)	Max Diagonal Image Size (m)	Max Diagonal Image Size (inch)	Max. Image Offset (m)
1.20	0.80	0.67	0.45	0.38	0.92	36.18	0.07
2.00	1.33	1.11	0.75	0.63	1.53	60.29	0.12
2.50	1.67	1.39	0.94	0.78	1.91	75.36	0.15
3.00	2.00	1.67	1.13	0.94	2.30	90.44	0.18
4.00	2.67	2.22	1.51	1.26	3.06	120.58	0.24
5.00	3.33	2.78	1.88	1.57	3.83	150.73	0.30
6.00	4.00	3.33	2.26	1.88	4.59	180.88	0.36
7.00	4.67	3.89	2.64	2.20	5.36	211.02	0.42
8.00	5.33	4.44	3.01	2.51	6.13	241.17	0.48
9.00	6.00	5.00	3.39	2.82	6.89	271.31	0.54
10.00	6.67	5.56	3.77	3.14	7.66	301.46	0.60
11.00	7.33	6.11	4.14	3.45	8.42	331.61	0.66
12.00	8.00	6.67	4.52	3.77	9.19	361.75	0.72

For guide purposes only

EH1020 is capable of 16:10/4:3 aspect ratio projection. When projecting a 16:10/4:3 image the image sizes, screen height and offset information will differ from the above.

Optoma Europe Ltd.
42 Caxton Way, Watford Business Park, Watford, Hertfordshire, UK. WD18 8QZ
www.optoma.eu



*Optoma guarantees that in normal use, Optoma DLP® colour quality will be indistinguishable from when new. Exclusions: (1) Guarantee is voided if the projector is subject to damage through misuse. (2) Guarantee may be void in industrial or commercial entertainment environments where dust or smoke is excessive (3) Guarantee will not apply if lamp brightness is below 50% due to wear or if the projector is not working due to other faults. (4) Over time worn lamps within all projector types will show a slight colour variance. **Typical lamp life achieved through testing. Will vary according to operational use and environment conditions. *** Optoma guarantees that in normal use, the DLP® imager will retain image quality for at least 5 years and provide consistent pixel performance. Exclusions: (1) Guarantee is voided if the projector is subject to damage through misuse. (2) Guarantee may be void in industrial or commercial environments where dust or smoke is excessive. Copyright © 2010, Optoma Europe Ltd. All other product names and company names used herein are for identification purposes only and may be trademarks or registered trademarks of their respective owners. Errors and omissions excepted, all specifications are subject to change without notice. DLP®, BrilliantColor™ and the DLP logo are registered trademarks of Texas Instruments.