

Think GAIA
For Life and the Earth

SANYO

PLC-XP100L

XGA Multimedia
Projector

Large-Screen Projection for a
Growing Number of Applications



Major Options

Part Number	LNS-W32	LNS-W31A	LNS-S30	LNS-S31	LNS-T31A	LNS-T32
Type	Short Fixed Lens	Wide Zoom Lens	Standard Zoom Lens	Standard Zoom Lens	Long Zoom Lens	Ultra Long Zoom Lens
Image						
Throw Distance	0.8 : 1	1.3 - 1.8:1	1.8 - 2.3 : 1	1.8 - 2.3 : 1	2.4 - 4.3 : 1	4.2 - 6.0 : 1
Focal Length	22.33 mm	34 ~ 48 mm	48.4 ~ 62.8 mm	48.2 ~ 62.6 mm	64 ~ 112 mm	112 ~ 155 mm
Lens Shift U/D	1 : 1	10 : 0 ~ 1 : 3	10 : 0 ~ 1 : 1	10 : 0 ~ 1 : 1	10 : 0 ~ 1 : 3	10 : 0 ~ 1 : 1
Motor Driven	No	Yes	Yes	Yes	Yes	Yes
F Value	2.5	2.5 - 3.1	1.8 - 2.1	1.7 - 2.0	2.0 - 2.9	2.1 - 2.7
Net Weight	1.6 kg	1.7 kg	0.84 kg	1.3 kg	1.9 kg	1.7 kg

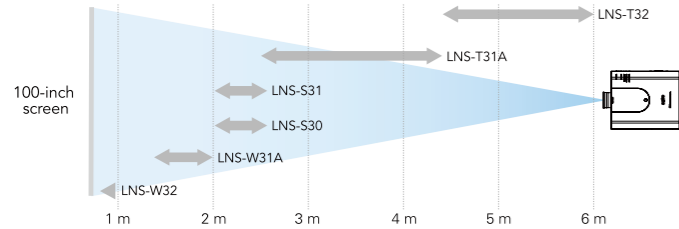

Unit: m	LNS-W32		LNS-W31A		LNS-S30		LNS-S31		LNS-T31A		LNS-T32	
	Fixed	Wide	Wide	Tele	Wide	Tele	Wide	Tele	Wide	Tele	Wide	Tele
40	-	1.0	1.4	1.4	1.8	1.4	1.8	1.8	3.3	3.5	4.8	
60	-	1.5	2.2	2.1	2.8	2.1	2.8	2.7	5.0	5.1	7.1	
80	1.3	2.0	2.9	2.9	3.8	2.9	3.7	3.7	6.8	6.8	9.4	
100	1.6	2.5	3.6	3.6	4.7	3.6	4.7	4.6	8.5	8.4	11.7	
150	-	3.8	5.5	5.4	7.2	5.5	7.1	7.0	12.8	12.6	17.5	
200	-	5.1	7.4	7.3	9.6	7.3	9.5	9.4	17.1	16.7	23.3	
250	-	6.4	9.2	9.1	12.0	9.2	11.8	11.8	21.4	20.8	29.1	
300	-	7.7	11.1	11.0	14.4	11.0	14.2	14.2	25.7	25.0	34.9	

External dimensions (unit: mm)

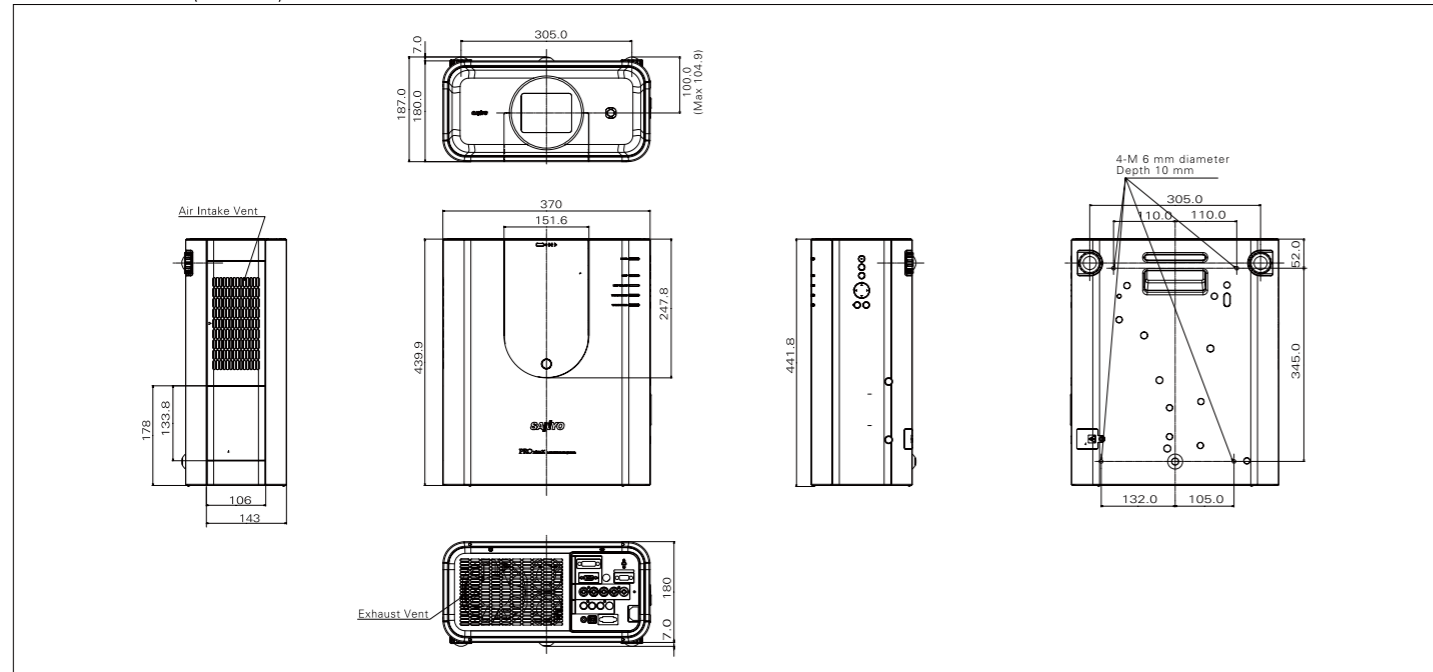

Specifications

Model number	PLC-XP100L
System	3-color LCD shutter projection system
Optics	Dichroic mirror separation / prism synthesis system
Size	1.3-inch x 3, 4:3 aspect ratio
Drive system	Polysilicon active matrix TFT
LCD panel	Number of pixels: 2,359,296 pixels: 786,432 (1,024 x 768) x 3
Configuration	Stripe
Lens	Optional
Lamp	330 W NSHA
Projection size	31 to 400 inches diagonally (Differs depending on installed lens)
Throw distance	Differs depending on installed lens
Color reproduction	Full color (1,070 million colors)
Brightness*1	6,500 lumens (LNS-S31 used)
Uniformity*1	90 %
Contrast ratio*1	2,000:1 (full on / full off)
Scanning frequency	H-sync: 15~100 kHz, V-sync: 48~100 Hz, Dot clock: 180 MHz or less
Resolution RGB	1,024 x 768 dots (Dot resizing for 1,600 x 1,200)
Computer compatibility	UXGA / SXGA+ / SXGA / WXGA (Compression) XGA / SVGA / VGA
Color system	PAL / SECAM / NTSC / NTSC 4.43 / PAL-M / PAL-N
Input terminals	Input 1 Image: DVI-D x 1 (HDCP compatible*2), mini D-sub 15pin x 1 Input 2 Image: BNC x 5 (RGBHV / YCbCr / Video) Input 3 Image: RCA x 3 (YCrCb / Video), S-Video x 1
Communication terminals	USB port: type B x 1 Serial port: D-sub 9-pin x 1 Wired remote jack: Stereo mini jack x 1
Output terminals	Image: Mini D-sub 15-pin x 1 (analog RGB)
Fan noise	31.8 dBA (Eco1 mode)
Operating temperature	5 ~ 40 °C
Power supply	AC 100~240 V, 50 / 60 Hz, auto voltage
Power consumption	490 W max (Eco mode: 392 w)
Dimensions (W x H x D)	14.57" x 7.36" x 17.32 (370 x 187 x 440 mm)
Weight	25.8 lbs (11.7 kg) (without lens)
Standard accessories	Owner's manual, warranty card, AC power cord (x 1), wired remote control cable (x 1), wireless / wired remote control (x 1), AA-size dry batteries (x 2) supplied, USB cable (x 1), D-sub15 to D-sub15 cable, PIN code label, lens attachment (x 1), light shield (x 2), lens spacer

*1 The figures are averages of all products at the time of shipment, and are indicated in accordance with JIS X8911: 2003 Data Projector Specifications Format. The measurement method and conditions are described in Appendix 2.
*2 DVI input images may not appear depending on the change of HDCP specifications.
*3 The USB interface cannot be guaranteed to operate with all USB equipment.
All trademarks and registered trademarks are the property of their respective trademark owners.

All products manufactured by the Projector Integrated Business Unit of SANYO's DI Company employ a quality management system that has undergone the inspection and registration process of the ISO 9001:2000 international standard.

SANYO's DI Company has received ISO 14001 certification for the environmental management system used in its factory.

Pixelworks ICs are used in this projector

<http://www.sanyo-lcdp.com/english/>

Caution: Please consult the instruction manual to ensure safe and proper operation of the product.

Distributed by:

SANYO

SANYO Electric Co. Ltd.
DI company
© 2007 SANYO Printed in JAPAN 2007.8 SI
SML084



Higher Brightness and Superior Images

Class-Leading 6,500-Lumen Brightness Excels in Large-Screen Projection

A bright 330-watt lamp (NSHA measurement) gives the PLC-XP100L a full 6,500 lumens of brightness, the highest in its class.* This makes it ideal for use in large halls, conference rooms and classrooms, as well as in digital signage applications.

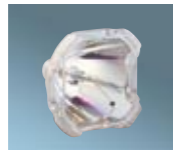

* For transmissive LCD projectors weighing 12 kg or less, as of July 4, 2007.

High Contrast Produces Superb Images with Crisp Blacks

Newly developed LCD panels work together with a high-contrast optical system to produce a contrast ratio of 2,000:1.

Automatic Image Compensation with Auto Picture Control Capability

Dynamic Auto Gamma Processing Achieving Impressive Contrast and Depth Enhancement: The PLC-XP100L brings the most appropriate contrast and sharpness to an image according to the image characteristics by optimizing the dynamic range of luminance signals and reflecting gamma setting and offset in a timely fashion. The result is a remarkable and outstanding depth in the image.



Realistic Image Reproduction with 10-Bit Video Signal Processing and a 12-Bit Gamma Circuit

Images are powerfully expressed with approximately 1.07 billion colors, thanks to 10-bit (1,024-step gradation) digital processing for each of the red, green and blue signals. The 12-bit gamma IC also renders every detail and nuance contained in high-definition images.



Vertical and Horizontal Edge Enhancement Process Delivers Natural Sharpness

Minimizing granular noise and enhancing only image outlines, the PLC-XP100L provides crisp and sharp images. Also, interaction with the image characteristics and timely effect modification allow this model to provide natural and seamless edge enhancement.



New Optical Engine

High-Brightness and Low-Electricity-Consumption Technology

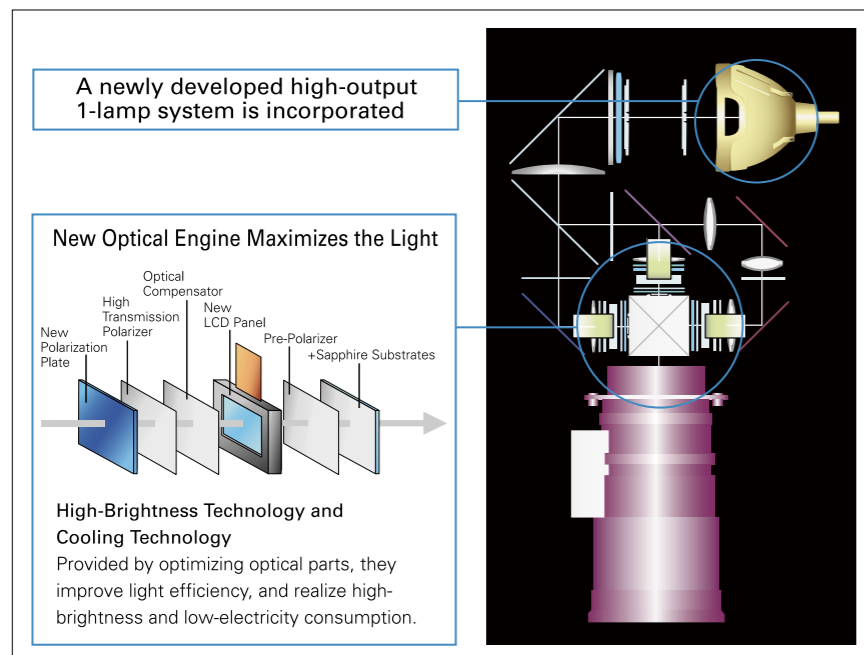

High Reliability

High Brightness

High Contrast

Easy Maintenance

Active Maintenance Filter (AMF)

The filter sensor detects the intake airflow volume, and advances a clean filter surface when the filter becomes soiled. The filter cartridge is also easily replaced without requiring any special tools.



Easier Lamp Replacement

Lamp replacement has been simplified to make maintenance easier.



One-Way Cooling Mechanism (Intake x1, Exhaust x1)

Intake and exhaust ports have been eliminated from various places on the projector (such as the bottom surface) and concentrated into one intake and one exhaust, both on the side, to solve dust-related problems (and improve cooling reliability).



Filter Clogging Detection Function

When it becomes time to clean the filter, or when the filter is clogged, the operator is informed by LED indicators and a message on the on-screen display (reducing heat damage to the interior).

*Cleaning time indication: LED turns on
Clog warning: LED blinks
Cabinet LED indicators

Easy Installation

Interchangeable Lenses (Optional)

The existing XP-series lenses can be used just as they are. Lens removal and attachment are also very easy.



*Lenses are sold as options.

Power Vertical / Horizontal Lens Shift

Featuring both vertical and horizontal lens shift (vertical: 0 to 50 %, horizontal: ±10 % (maximum)), the PLC-XP100L enables intuitive operation for easy on-site setup.



Vertical Installation

The PLC-XP100L can also be installed to project images upward or downward.

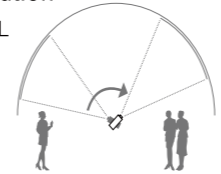

Easy Control

PJ-Net Organizer

To use the PJ-Net technology, simply attach the PJ-Net Organizer to the projector

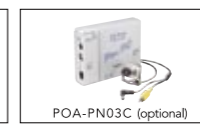

PJ Master

The PJ Master software allows centralized control of PJ-Net Organizer-mounted projectors over a network. Install PJ Master on your PC or server.



PJ-Net Organizer Usage Example

Projectors connected by the PJ-Net Organizer let you access the following advanced centralized control
*Monitoring the internal temperature of the projector *Notification of lamp-related information (e.g. malfunction, operating hours, etc.)
*Comprehensive management of network-connected projectors *Database applications for all acquired data

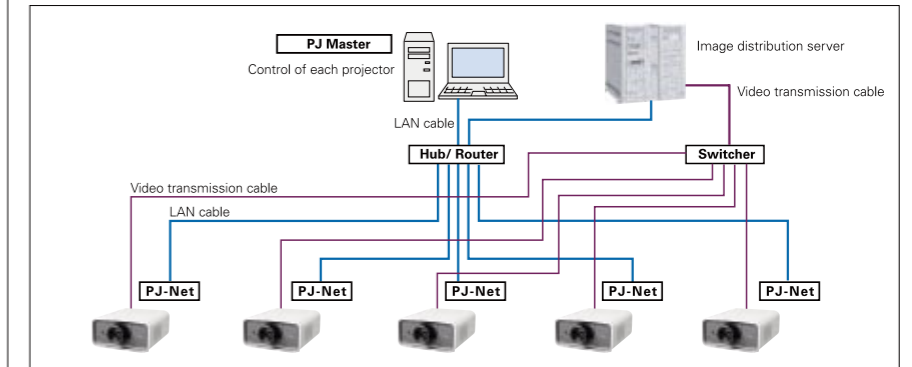

Network Capture Function
Web-based Management

Network Viewer Function
E-mail Alert Function Sends Messages

Other Features

Built-in Test Pattern

Makes on-site setup easier by serving as a guide for setting adjustments. (Includes a total of 8 built-in patterns.)

Silence Design (31.8 dB, in ECO mode)

The operating noise is hardly noticeable even in quiet settings like conference or AV rooms.

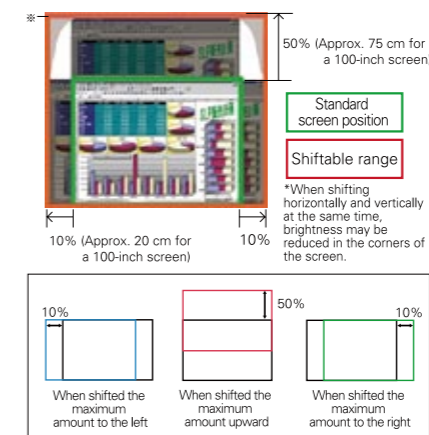

XGA Multimedia Projector
PLC-XP100L

Brightness of 6,500 lumens