

SMS PROJECTOR SHORT THROW MOBILE MOTORIZED



Forget about the projector room.

The motor-driven height adjustment and rotatable projector pillar allow the system to pass through doorways easily. Now with a universal fitting that can be used with most currently available interactive boards. A new broader foot makes it easier to get close to the stand. Choose between white and black universal slide to match the projector. Ideal for use anywhere where equipment needs to be moved often.

- | | | | |
|---|--|--|--|
| <input type="radio"/> Ceiling | <input type="radio"/> Heavy weight | <input type="radio"/> Fixed | <input checked="" type="radio"/> Variable |
| <input type="radio"/> Wall | <input type="radio"/> Middle weight | <input type="radio"/> Swivel | <input type="radio"/> UniSlide |
| <input checked="" type="radio"/> Floor | <input checked="" type="radio"/> Light weight | <input type="radio"/> Tilt | <input type="radio"/> Hidden |
| <input type="radio"/> Table | | <input type="radio"/> 3D | <input type="radio"/> Double |
| | | <input checked="" type="radio"/> Mobile | |

SMS PROJECTOR SHORT THROW MOBILE MOTORIZED

INFO

- Finish: White/silver/aluminium/black.
- Maximum load for projector pillar: 8 kg.
- Maximum load for main pillar: 50 kg.
- Tilt of projector slide: $\pm 15^\circ$.
- Adjustable: The main pillar can be electrically adjusted in height to allow the stand to pass through doorways easily. The projector can be suspended at a freely chosen position anywhere on the pillar.

Other information: One universal fitting that can be used with most currently available interactive boards – the same fitting is ordered for all brands of board.

We reserve the right to introduce changes in the product specifications.

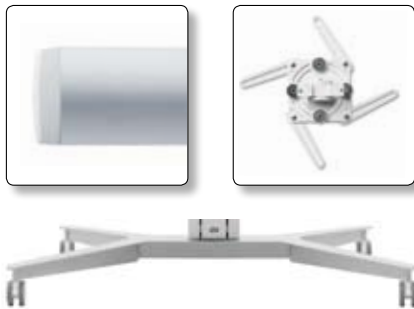

Now with white plastic fittings, a cable sock to conceal the cables, a universal slide for projectors in white and black and a broader foot.

ART. NO

ART. NO	DESCRIPTION
AE018010EU-P0	Standard Package SMS Projector Short Throw Mobile A/B
AE018011EU-P0	Standard Package SMS Projector Short Throw Mobile A/W
AE018010UK-P0	Standard Package SMS Projector Short Throw Mobile A/B
AE018011UK-P0	Standard Package SMS Projector Short Throw Mobile A/W
AE018010CH-P0	Standard Package SMS Projector Short Throw Mobile A/B
AE018011CH-P0	Standard Package SMS Projector Short Throw Mobile A/W

White fittings projector pillar:

FS000680AW-P2	SMS Proj Short Throw 680 mm A/W
FS001202AW-P2	SMS Proj Short Throw 1200 mm A/W
FS001450AW-P2	SMS Proj Short Throw 1450 mm A/W

Black fittings projector pillar:

FS000680-P2	SMS Proj Short Throw 680 mm A/B
FS001202-P2	SMS Proj Short Throw 1200 mm A/B
FS001450-P2	SMS Proj Short Throw 1450 mm A/B

Accessories:

PD100001EU	SMS Power Socket EU Black Schuko
PD100002CH	SMS Power Socket CH Black
PD100003UK	SMS Power Socket UK Black
PD400001	SMS X Media Box White
PD400003	SMS X Media Box Oak
PD400004	SMS X Media Box Walnut
PD300005-P0	SMS X Shelf White
PD300006-P0	SMS X Shelf Oak
PD300007-P0	SMS X Shelf Walnut
AE018002	SMS X Remote Control Kit

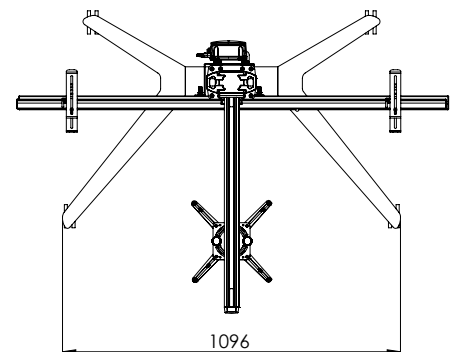
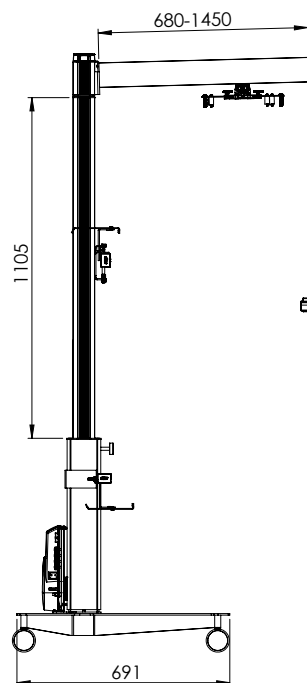
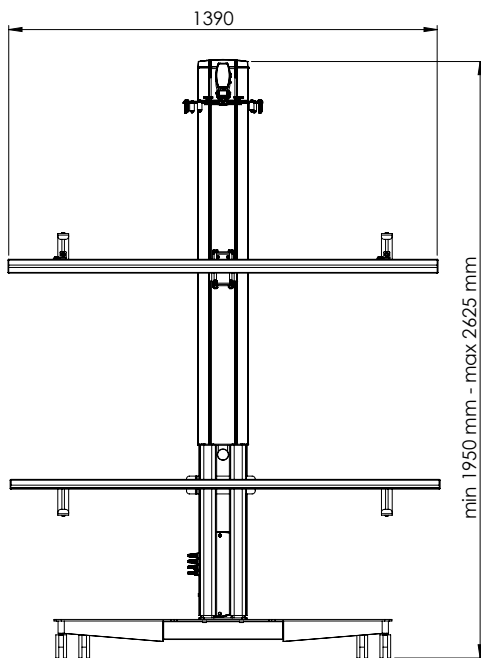

SMART MEDIA SOLUTIONS

www.SmartMediaSolutions.se