S P E C F I L E

Product Number : PT-**CX301R**

Product Name : Ultra Short-Throw DLP™ Projector

Specifications

Main unit

Power supply		100–240 V AC, 3.6–1.5 A, 50/60 Hz
Power consumption		340 W (0.5 W when STANDBY MODE set to ECO,*1 6.0 W when STANDBY MODE set to NETWORK.)
DLP™ chip	Panel size	14.0 mm (0.55 inches) diagonal (4:3 aspect ratio)
	Display method	DLP™ chip × 1, DLP™ system
	Pixels	786,432 (1,024 × 768) pixels
Lens		Fixed (0.44:1 throw ratio), manual focus, F 2.6, f 5.27 mm
Lamp		280 W UHM lamp × 1
Screen size		1.52–2.29 m (60–90 inches) diagonally, 4:3 aspect ratio
Colors		Full color (16,777,216 colors)
Brightness*2		3,100 lumens (LAMP POWER: NORMAL)
Center-to-corner uniformity*2		80%
Contrast*2		8,000:1 (full on/off, During RGB signal input, LAMP POWER: NORMAL)
Resolution		1,024 × 768 pixels (Input signals that exceed this resolution will be converted to 1,024 × 768 pixels.)
Scanning frequency	HDMI	fh: 15 kHz–100 kHz, fv: 24 Hz–120 Hz, dot clock: 25 MHz–162 MHz
	RGB	fh: 15 kHz–100 kHz, fv: 24 Hz–120 Hz, dot clock: 162 MHz or lower
	YPbPr (YCbCr)	525i (480i): fh 15.75 kHz; fv 60 Hz, 625i (576i): fh 15.63 kHz; fv 50 Hz, 525p (480p): fh 31.50 kHz; fv 60 Hz, 625p (576p): fh 31.25 kHz; fv 50 Hz, 750 (720)/60p: fh 45.00 kHz; fv 60 Hz, 750 (720)/50p: fh 37.50 kHz; fv 50 Hz, 1125 (1080)/60i: fh 33.75 kHz; fv 60 Hz, 1125 (1080)/50i: fh 28.13 kHz; fv 50 Hz 1125 (1080)/24p: fh 27.00 kHz; fv 24 Hz 1125 (1080)/60p: fh 67.50 kHz; fv 60 Hz 1125 (1080)/50p: fh 56.25 kHz; fv 50 Hz
	Video/S-Video	fh: 15.75/15.63 kHz, fv: 50/60 Hz [NTSC/NTSC4.43/PAL/PAL60/PAL-N/PAL-M/SECAM]
Keystone correction range		Vertical: ±15°
Installation		Ceiling/floor, front/rear (Menu setting)
Built-in speaker	Size	7 x 3 cm (2-3/4 x 1-3/16 inches) (oval-shaped) × 1
	Output power	10 W (monaural)
Terminals	HDMI IN	HDMI 19-pin × 1, HDCP compatible, Deep color compatible 525p (480p), 625p (576p), 525p (480p), 625p (576p), 750 (720)/60p, 750 (720)/50p, 1125 (1080)/60i, 1125 (1080)/50i, 1125 (1080)/24p, 1125 (1080)/60p, 1125 (1080)/50p VGA (640 × 480)–WSXGA+ (1,680 × 1,050), Audio signal: linear PCM (sampling frequencies: 48 kHz, 44.1 kHz, 32 kHz)
	COMPUTER (RGB) 1/2 IN R, G, B	D-sub HD 15-pin (female) × 1 G: 0.7 Vp-p (1.0 Vp-p for sync on G), 75 ohms; B, R: 0.7 Vp-p, 75 ohms; HD/VD, SYNC: high impedance, TTL, positive/negative automatic
	Y, Pb (Cb), Pr (Cr)	Y: 1.0 Vp-p (including sync signal); Pb (Cb), Pr (Cr): 0.7 Vp-p, 75 ohms
	MONITOR (RGB) OUT R, G, B	D-sub HD 15-pin (female) × 1 (Outputs signals selected from RGB input 1/2.) G: 0.7 Vp-p (1.0 Vp-p for sync on G), 75 ohms; B, R: 0.7 Vp-p, 75 ohms; HD/VD, SYNC: high impedance, TTL, positive
	Y, Pb (Cb), Pr (Cr)	Y: 1.0 Vp-p (including sync signal); Pb (Cb), Pr (Cr): 0.7 Vp-p, 75 ohms
	VIDEO IN	Pin jack × 1, 1.0 Vp-p, 75 ohms
	S-VIDEO IN	Mini DIN 4-pin × 1, Y: 1.0 Vp-p; C: 0.286 Vp-p, 75 ohms

COMPUTER 1 AUDIO IN	M3 (L, R) × 1, 0.5 Vrms
COMPUTER 2 AUDIO IN	M3 (L, R) × 1, 0.5 Vrms
VIDEO/S-VIDEO AUDIO IN	Pin jack × 2 (L/R × 1), 0.5 Vrms
AUDIO OUT	M3 (L, R) × 1 (monitor out: 0–2.0 Vrms, variable)
SERIAL IN	D-sub 9-pin (female) × 1, for external control (RS-232C compliant)
LAN	RJ-45 × 1, for network connection, 100Base-TX/10Base-T, compliant with PLink™
MiniUSB	MiniUSB × 1 (For interactive function)
Power cord length	3.0 m (9 ft 10 in)
Cabinet materials	Molded plastic (PC)
Dimensions (W × H × D)	357 mm × 250 mm* ³ × 367 mm (14-1/16 × 9-27/32* ³ × 14-29/64 inches)
Weight	Approximately 7.8 kg (17 lbs)
Operation noise	37 dB (LAMP POWER: NORMAL), 33 dB (LAMP POWER: ECO)
Operating temperature	5–40 °C (41–104 °F) up to 750 m (2,500 ft) above sea level, 5–35 °C (41–95 °F) between 750 m and 1,500 m (2,500 ft and 5,000 ft) above sea level. 5–30 °C (41–86 °F) between 1,500 m and 3,000 m (5,000 ft and 10,000 ft) above sea level.
Operating humidity	20%–80% (no condensation)
Remote control unit	
Power supply	3 V DC (Lithium coin cell battery × 1)
Operation range* ⁴	Approximately 8 m (26.3 ft) when operated from directly in front of the signal receptor
Dimensions (W × H × D)	41 × 87 × 7 mm (1-39/64 × 3-27/64 × 9/32 inches)
Weight	Approx. 23 g (0.8 oz) (including Lithium coin cell battery)
Supplied accessories	
	Power cord (× 1) (× 2 for PT-CX301REA)
	Power code cover (× 1)
	Power code holder (× 1)
	Wireless remote control unit (× 1)
	Lithium coin cell battery for remote control (× 1)
	Computer cable (1.8 m) (× 1)
	Interactive Pen (× 2)
	AAA type battery (× 4)
	USB cable (5.0 m) (× 1)
	Software CD-ROM (Interactive function manual, LightPenIII) (× 1)
Optional accessories	
Ceiling mount bracket	ET-PKV100H (for high ceilings) ET-PKV100S (for low ceilings)
Bracket assembly	ET-PKC200B
Wall mount bracket	ET-PKC200W
Replacement lamp unit	ET-LAC300
Interactive Pen	ET-PEN100
Interactive Pointer	ET-PNT100

Weights and dimensions shown are approximate. Specifications subject to change without notice.

*1 When the standby mode is set to eco, network functions such as LAN Standby On and MONITOR OUT/AUDIO OUT terminals do not work.

*2 Measurement, measuring conditions, and method of notation all comply with ISO 21118 international standards.

*3 With legs at shortest position.

*4 Operation range differs depending on environments.

Dimensions

unit : mm (inch)

NOTE: This illustration is not drawn to scale.

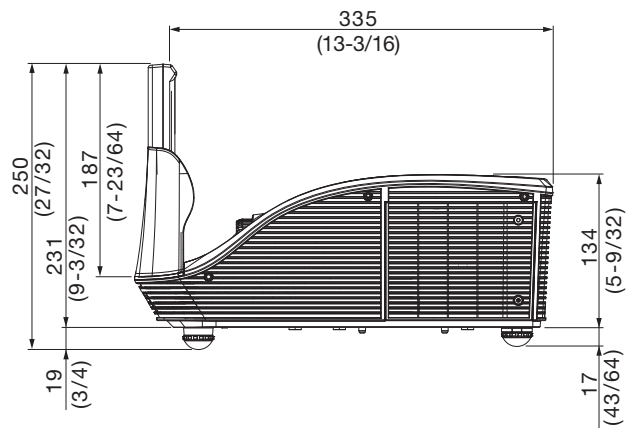
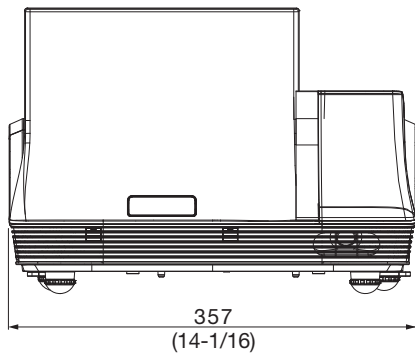
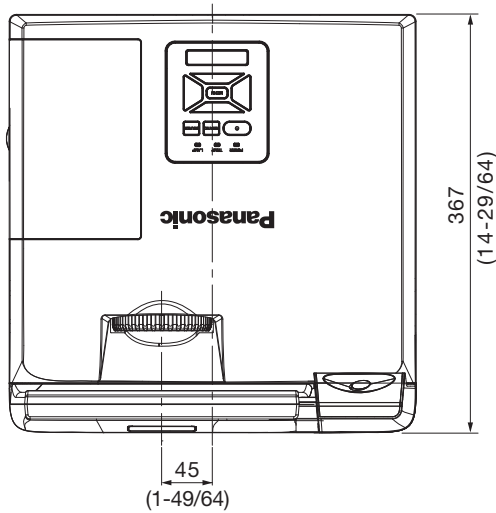

Terminals

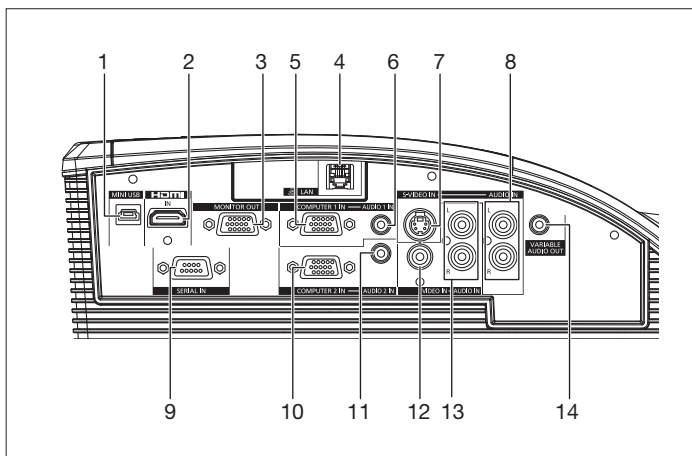

- 1 MiniUSB
- 2 HDMI input
- 3 Monitor output
- 4 LAN connector
- 5 Computer 1 input
- 6 Audio input for computer 1
- 7 S-Video input
- 8 Audio input for S-Video
- 9 Serial input
- 10 Computer 2 input
- 11 Audio input for computer 2
- 12 Video input
- 13 Audio input for video
- 14 Audio output

Standard setting-up position

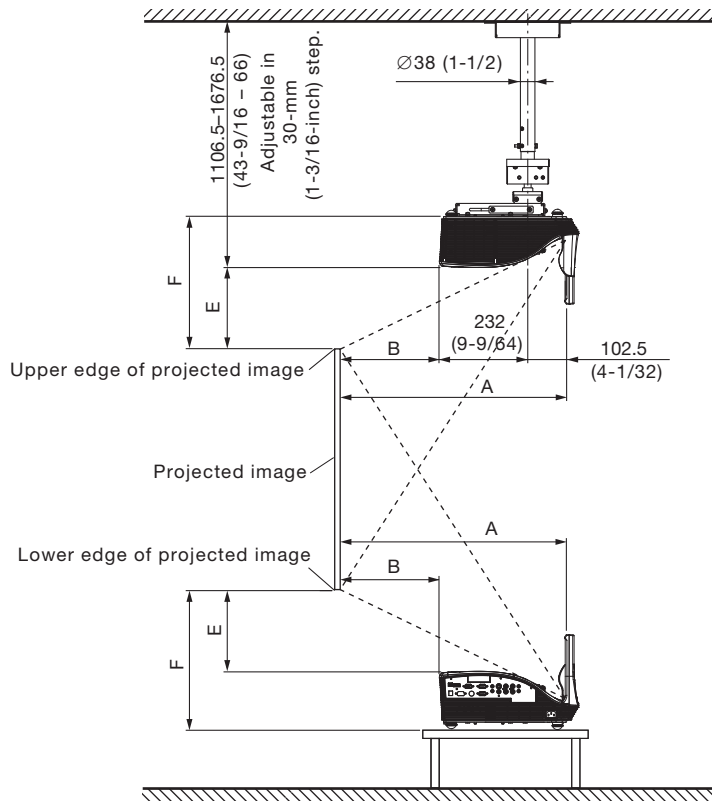

NOTE:

Illustrations show the projector installed using optional ceiling mount bracket ET-PKV100H and bracket assembly ET-PKC200B.

This illustration is not drawn to scale.

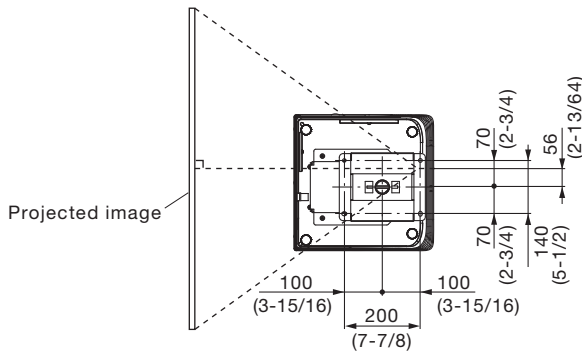

unit : mm (inch)

Caution:

- All construction work should be done by a qualified technician.
- When mounting to the ceiling, use the special mounting bracket. Furthermore, in order to prevent it from falling down from the ceiling, use the supplied wire on the mounting bracket.

Projection distance for 4:3 aspect ratio screen

Unit: meters

Screen size (inch, diagonal)	A: Distance from the edge of the projection window to the screen	B: Distance from the projector front to the screen	E: Height from the edge of the screen to the top of the projector	F: Height from the edge of the screen to the bottom of the projector
60	0.52	0.19	0.18	0.26
70	0.62	0.28	0.23	0.30
80	0.71	0.38	0.27	0.34
90	0.80	0.47	0.31	0.39

Unit: feet

Screen size (inch, diagonal)	A: Distance from the edge of the projection window to the screen	B: Distance from the projector front to the screen	E: Height from the edge of the screen to the top of the projector	F: Height from the edge of the screen to the bottom of the projector
60	1.7	0.6	0.6	0.9
70	2.0	0.9	0.8	1.0
80	2.3	1.2	0.9	1.1
90	2.6	1.5	1.0	1.2

Calculation of the projection distance

For a screen size different from the above, use the equation below to calculate the projection distance.

Aspect ratio 4:3

$$A (m) = (\text{diagonal screen size in inches}) \times 0.00940 - 0.0415$$

NOTE:

Distances calculated with the above equations will include a slight error.

Installable angle

Install the projector at an angle within the range shown below.

• Vertical direction

The projector may be installed at a vertical angle of $\pm 10^\circ$.

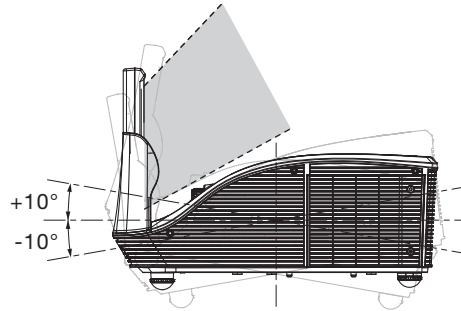
**• Horizontal direction**

The projector may be installed at a horizontal angle of $\pm 10^\circ$.

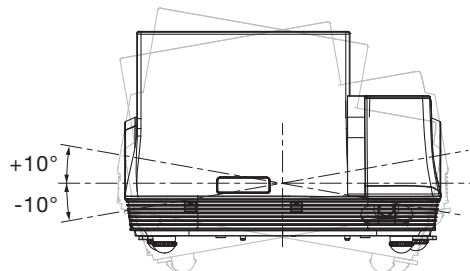

List of compatible signals

The signals that can be input to this projector are shown in the table below. Horizontal scanning frequencies of 15 kHz to 100 kHz, vertical scanning frequencies of 24 Hz to 120 Hz, and a dot clock of 162 MHz maximum can be input.

NOTE: The native resolution of this projector is 1,024 × 768 pixels. If the display resolution of the input signal is different from the native resolution, image compression or expansion will be used to convert the input signal to a level within the native resolution.

Display mode	Display resolution (dots) ¹	Scanning frequency H (kHz)	Scanning frequency V (kHz)	Dot clock frequency (MHz)	Format
NTSC/NTSC4.43/PAL-M/PAL60	720 × 480i	15.7	59.9	–	VIDEO/S-VIDEO
PAL/PAL-N/SECAM	720 × 576i	15.6	50.0	–	
525i (480i)	720 × 480i	15.7	59.9	27.0	HDMI
		15.7	59.9	13.5	YCbCr
625i (576i)	720 × 576i	15.6	50.0	27.0	HDMI
		15.6	50.0	13.5	YCbCr
525p (480p)	720 × 483	31.5	59.9	27.0	HDMI/YPbPr
625p (576p)	720 × 576	31.3	50.0	27.0	
750(720)/60p	1280 × 720	45.0	60.0	74.3	
750(720)/50p		37.5	50.0	74.3	
1125(1080)/60i	1920 × 1080i	33.8	60.0	74.3	
1125(1080)/50i		28.1	50.0	74.3	
1125(1080)/24p	1920 × 1080	27.0	24.0	74.3	
1125(1080)/60p		67.5	60.0	148.5	
1125(1080)/50p		56.3	50.0	148.5	
VGA	640 × 480	31.5	59.9	25.2	HDMI/RGB
		35.0	66.7	30.2	
		37.5	75.0	31.5	
		37.9	72.8	31.5	
		43.3	85.0	36.0	
		61.9	120.0	52.5	
	720 × 400	31.5	70.1	28.3	
SVGA	800 × 600	35.1	56.3	36.0	
		37.9	60.3	40.0	
		46.9	75.0	49.5	
		48.1	72.2	50.0	
		53.7	85.1	56.3	
		77.4	119.9	83.0	
MAC16	832 × 624	49.1	74.6	57.3	
XGA	1024 × 768	48.4	60.0	65.0	
		56.5	70.1	75.0	
		60.0	75.0	78.8	
		68.7	85.0	94.5	
		99.0	119.8	137.8	
WXGA	1280 × 720	44.8	60.0	74.5	
	1280 × 800	49.7	59.8	83.5	
	1366 × 768	47.7	59.8	84.8	
	1440 × 900	59.9	59.9	106.5	
MAC21	1152 × 870	68.7	75.1	100.0	
SXGA	1280 × 960	60.0	60.0	108.0	
		75.2	75.0	130.0	
	1280 × 1024	64.0	60.0	108.0	
		77.0	72.0	133.0	
		80.0	75.0	135.0	
SXGA+	1400 × 1050	65.3	60.0	121.8	
UXGA	1600 × 1200	75.0	60.0	162.0	
WSXGA+	1680 × 1050	65.3	60.0	146.3	

*1 The “i” appearing after the resolution indicates an interlaced signal.

3D-compliant signal list

The 3D signals that can be input to this projector are as follows.

Display mode	Display resolution (dots) ¹	Scanning frequency		Dot clock frequency (MHz)	HDMI				Computer1/2	Video/S-Video	
		H (kHz)	V (kHz)		Frame packing	Side by side	Top and bottom	Frame sequential	Frame sequential	Frame sequential	Filled sequential
750(720)/60p	1280 × 720	45.0	60.0	74.3	○	×	○	×	×	×	×
750(720)/50p		37.5	50.0	74.3	○	×	○	×	×	×	×
1125(1080)/60i	1920 × 1080i	33.8	60.0	74.3	×	○	×	×	×	×	×
1125(1080)/50i		28.1	50.0	74.3	×	○	×	×	×	×	×
1125(1080)/24p	1920 × 1080	27.0	24.0	74.3	○	×	○	×	×	×	×
VGA	640 × 480	61.9	119.5	52.6	×	×	×	○	○	×	×
SVGA	800 × 600	77.4	119.9	83.0	×	×	×	○	○	×	×
XGA	1024 × 768	99.0	119.8	137.8	×	×	×	○	○	×	×
Video/S-Video	-	-	-	-	×	×	×	-	×	○	○

Serial connector

The serial connector complies with RS-232C. To control the projector from a personal computer, commands must be input through communication software, based on the format and satisfying the communication conditions shown below.

Pin assignments and signal names

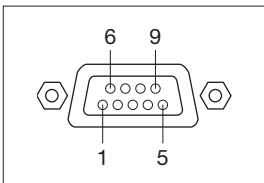

No.	Signal name	Description	No.	Signal name	Description
1	-	NC	6	-	NC
2	TXD	Send data	7	CTS	Connected internally
3	RXD	Receive data	8	RTS	Connected internally
4	-	NC	9	-	NC
5	GND	Ground			

D-sub 9-pin (female) Serial input

Communication conditions (factory setting)

Signal level	RS-232C-compliant
Synchronization method	Start-stop synchronization
Baud rate	19,200 bps
Parity	None
Character length	8 bits
Stop bit	1 bit
X parameter	None
S parameter	None

Basic format

Transmission from the computer begins with STX, then the ID, command, parameter, and ETX are sent in this order. Add parameters according to the details of control.

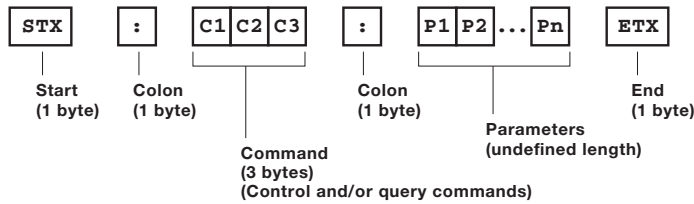

* STX and ETX are character chords. STX is 02 and ETX is 03 when expressed in hexadecimal.

CAUTION

- It may not be possible to send or receive commands for about 10 to 60 seconds when the lamp is first turned on. If this occurs, wait for 60 seconds, then try sending or receiving again.
- When sending multiple commands, be sure to wait for at least 0.5 second after receiving a response from the projector before sending the next command.
- Additional time is sometimes required for response due to processing inside the projector. Set the time-out period for command response to 10 seconds or more.

Cable specifications

Projector		PC (DTE)	
1	NC	NC	1
2			2
3			3
4	NC	NC	4
5			5
6	NC	NC	6
7			7
8			8
9	NC	NC	9

Control commands

Command : Parameter	Function		Callback
PON	POWER (STANDBY)	Standby power on	PON
POF		Standby power off	POF
IIS:HD1	INPUT SELECT	HDMI	IIS:HD1
IIS:RG1		RGB 1	IIS:RG1
IIS:RG2		RGB 2	IIS:RG2
IIS:VID		Video	IIS:VID
IIS:SVD		S-Video	IIS:SVD
OSH:0	AV MUTE	AV mute off	OSH:0
OSH:1		AV mute on	OSH:1

* Do not send PON, POF or OSH commands continuously in a short period of time. Doing so may burst the lamp or shorten the lamp replacement cycle.

* When a command that cannot be executed during standby mode is sent, the projector will send an ER401 command in reply.

Status request commands

Command:Parameter	Function	Callback	Description
QPW	Main power status	000	Standby
		001	On
Q\$S	Lamp on status	0	Standby
		1	Lamp on control in progress
		2	Lamp on
		3	Lamp off control in progress
QSH	AV mute function status	0	Off
		1	On
QIN	Input signal status	HD1	HDMI
		RG1	RGB 1
		RG2	RGB 2
		VID	Video
		SVD	S-Video
QVX:RTMI0	Projector run time	p1p2p3p4p5	00000h–99999h
Q\$L	Lamp run time	p1p2p3p4	0000h–9999h
QTM:0	Temperature status	p1p2p3p4 / p5p6p7p8 ^(*)	p0 = Internal temperature

*1 p1p2p3p4: Celsius (°C), p5p6p7p8: Fahrenheit (°F)

NOTE: If a wrong command is received, the projector will send an ER401 or ER402 command to the computer.

Command example

To set the AV mute function off, send the command as shown below.

```

STX   OSH   :   0   ETX
  |       |       |       |
  Start  Command Parameter End
    
```

NOTE: When sending commands without parameters, a colon (:) is not necessary.

Notes on projector placement and operation

The projector uses a high-wattage lamp that becomes very hot during operation. Please observe the following precautions.

1. Never place objects on top of the projector while it is operating.
2. Make sure there is the unobstructed space as shown below or more around the projector's exhaust openings. In addition to this space, also ensure that there is a sufficient work space for removing and installing the lamp, air filter and other parts.
3. Make sure that nothing blocks the projector's air intake and exhaust openings. Also, install the projector so that cool or hot air from other air conditioning equipment does not flow directly toward the projector's air intake or exhaust openings.
4. Do not install the projector in an enclosed space. If it is necessary to install it in an enclosed space, add a separate ventilation system. If ventilation is insufficient, hot air will accumulate at the intake opening. This may cause the projector's protective circuit to interrupt projector operation.

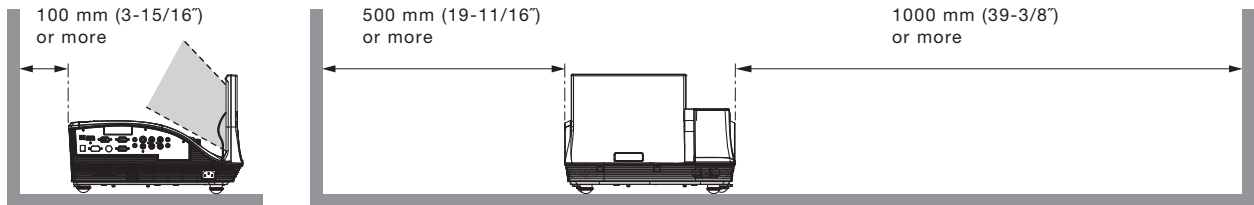

Direction of air intake and exhaust

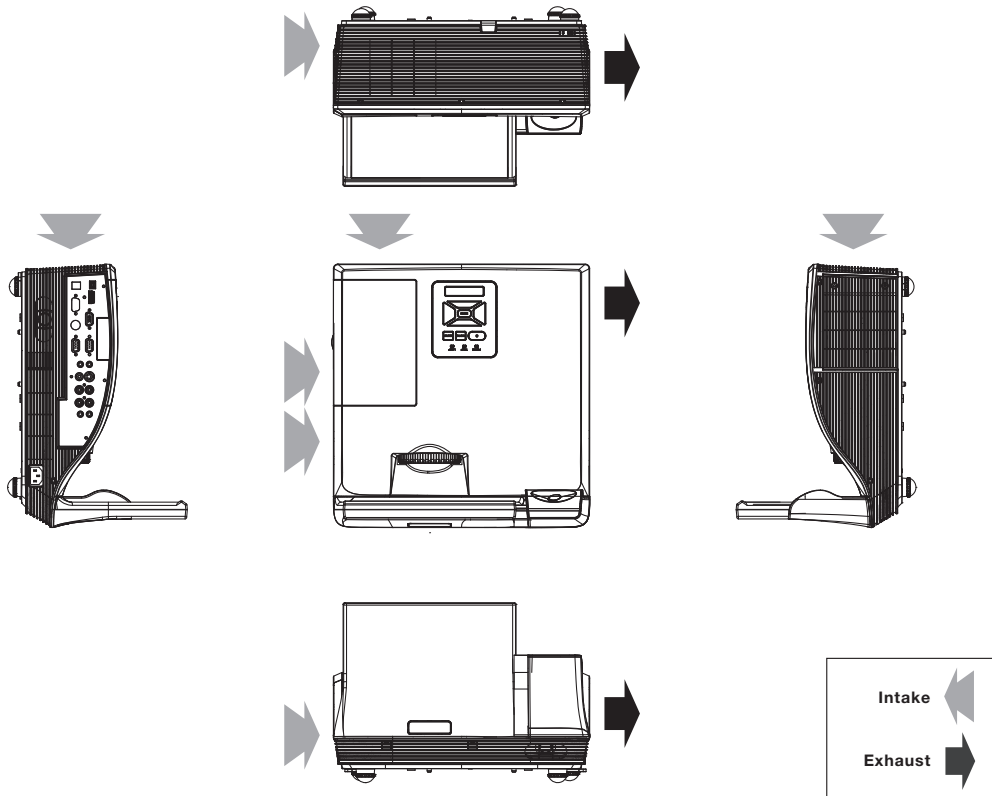

Operating the projector continuously

1. If the projector is to be operated continuously 22 hours or more, lamp replacement cycle duration becomes shorter.
2. The lamp replacement cycle duration becomes shorter if the projector is operated repeatedly for short periods (one hour or less).

Weights and dimensions shown are approximate. Specifications and appearance are subject to change without notice.
Product availability differs depending on region and country. This product may be subject to export control regulations.

DLP and the DLP logo are trademarks of Texas Instruments.
PJLink is a registered trademark, or a trademark application has been filed, in Japan, the United States, and other countries and regions.
All other trademarks are the property of their respective trademark owners.