

---

**S P E C F I L E**

---

Product Number : **PT-EX510/EX510L**

Product Name : LCD Projectors

**Specifications**

**Main unit**

Power supply		100–240 V AC, 50/60 Hz
Power consumption		485 W (0.3 W with STANDBY MODE set to ECO* <sup>1</sup> , 4 W with STANDBY MODE set to NORMAL, 34 W with in STANDBY MODE of Audio Setting set to on.)
Optical system		Dichroic mirror separation/prism synthesis system
LCD panel	Panel size	20.0 mm (0.79 inches) diagonal (4:3 aspect ratio)
	Display method	Transparent LCD panel (× 3, R/G/B)
	Pixels	786,432 (1,024 × 768) × 3, total of 2,359,296 pixels
	Pixel configuration	Stripe
Lens		Powered zoom/focus lens (1.7–2.8:1), F 1.7–2.3, f 26.9–45.4 mm Optional powered zoom/focus lenses and fixed-focus lens
Lamp		335 W UHM lamp
Screen size		1.02–10.16 m (40–400 inches), 4:3 aspect ratio
Brightness* <sup>2</sup>		5,300 lumens (LAMP POWER: AUTO/NORMAL, Dynamic mode, Standard lens)
Center-to-corner uniformity* <sup>2</sup>		90%
Contrast* <sup>2</sup>		2,000:1 (full on / full off, LAMP POWER: AUTO, Dynamic mode)
Resolution		1,024 × 768 pixels
Scanning frequency	HDMI/DVI-D	fH: 15–100 kHz, fV: 24–120 Hz, dot clock: 25 MHz–162 MHz (VGA: 640 × 480 pixels to WUXGA: 1,920 × 1,200 pixels, VESA CVT-RB compliant, compatible with HDCP)
	RGB	fH: 15–100 kHz, fV: 24–120 Hz, dot clock: up to 162 MHz
	YPbPr (YCbCr)	480i (525i): fH 15.73 kHz; fV 59.94 Hz, 576i (625i): fH 15.63 kHz; fV 50 Hz, 480p (525p): fH 31.47 kHz; fV 59.94 Hz, 576p (625p): fH 31.25 kHz; fV 50 Hz, 720 (750)/60p: fH 45.00 kHz; fV 60 Hz, 720 (750)/50p: fH 37.50 kHz; fV 50 Hz, 1080 (1125)/60i: fH 33.75 kHz; fV 60 Hz, 1080 (1125)/50i: fH 28.13 kHz; fV 50 Hz, 1080 (1125)/25p: fH 28.13 kHz; fV 25 Hz, 1080 (1125)/24p: fH 27.00 kHz; fV 24 Hz, 1080 (1125)/24sF: fH 27.00 kHz; fV 48 Hz, 1080 (1125)/30p: fH 33.75 kHz; fV 30 Hz, 1080 (1125)/60p: fH 67.50 kHz; fV 60 Hz, 1080 (1125)/50p: fH 56.25 kHz; fV 50 Hz
	Video/YC	fH: 15.73 kHz, fV: 59.94 Hz [NTSC/NTSC4.43/PAL-M/PAL60] fH: 15.63 kHz, fV: 50 Hz [PAL/PAL-N/SECAM]
Optical axis shift		Vertical: ±50% (powered), horizontal: ±10% (powered) <b>NOTE: Optical axis shift function cannot be operated when used with the ET-ELW21.</b>
Keystone correction range		Vertical: ±40° (with vertical correction only) Horizontal: ±30° (with horizontal correction only)
Installation		Ceiling/floor, front/rear
Built-in speaker	Size	3.7 cm (1-15/32 inches) (round) × 1
	Output power	10 W (monaural)

Terminals	HDMI IN	HDMI 19-pin × 1, Deep Color, HDCP compatible 480i(525i) <sup>*3</sup> , 576i(625i) <sup>*3</sup> , 480p(525p), 576p(625p), 720(750)/60p, 720(750)50p, 1080(1125)/60i, 1080(1125)/50i, 1080(1125)/25p, 1080(1125)/24p, 1080(1125)/24sF, 1080(1125)/30p, 1080(1125)/60p, 1080(1125)/50p VGA (640 × 400)–WUXGA <sup>*4</sup> (1,920 × 1,200) Audio signal: linear PCM (sampling frequencies: 48 kHz, 44.1 kHz, 32 kHz)
	DVI-D IN	DVI-D 24-pin × 1, DVI 1.0 compliant, compatible with HDCP, compatible with single link only 480i(525i) <sup>*3</sup> , 576i(625i) <sup>*3</sup> , 480p(525p), 576p(625p), 720(750)/60p, 720(750)50p, 1080(1125)/60i, 1080(1125)/50i, 1080(1125)/25p, 1080(1125)/24p, 1080(1125)/24sF, 1080(1125)/30p, 1080(1125)/60p, 1080(1125)/50p VGA (640 × 400)–WUXGA <sup>*4</sup> (1,920 × 1,200)
	RGB1 IN R, G, B  Y, P <sub>B</sub> (C <sub>B</sub> ), P <sub>R</sub> (C <sub>R</sub> )	D-sub HD 15-pin (female) × 1 R: 0.7 Vp-p, 75 ohms; G: 0.7 Vp-p (1.0 Vp-p for sync on G), 75 ohms; B: 0.7 Vp-p, 75 ohms; HD/VD, SYNC: high impedance, TTL (positive/negative) Y: 1.0 Vp-p (including sync signal); P <sub>B</sub> (C <sub>B</sub> ), P <sub>R</sub> (C <sub>R</sub> ): 0.7 Vp-p, 75 ohms <b>NOTE: SYNC/HD and VD terminals do not accept tri-level sync signals.</b>
	RGB2 IN R, G, B  Y, P <sub>B</sub> (C <sub>B</sub> ), P <sub>R</sub> (C <sub>R</sub> )	BNC × 5 (RGB/YP <sub>B</sub> PR/YC <sub>B</sub> CR × 1) R: 0.7 Vp-p, 75 ohms; G: 0.7 Vp-p (1.0 Vp-p for sync on G), 75 ohms; B: 0.7 Vp-p, 75 ohms; HD/VD, SYNC: high impedance, TTL (positive/negative) <b>NOTE: SYNC/HD and VD terminals do not accept tri-level sync signals.</b> Y: 1.0 Vp-p (including sync signal); P <sub>B</sub> (C <sub>B</sub> ), P <sub>R</sub> (C <sub>R</sub> ): 0.7 Vp-p, 75 ohms
	S-Video IN	Y: 1.0 Vp-p; C: 0.286 Vp-p, 75 ohms
	VIDEO IN	PIN Jack × 1, 1.0 Vp-p, 75 ohms
	MONITOR OUT	D-sub HD 15-pin (female) × 1 R: 0.7 Vp-p, 75 ohms; G: 0.7 Vp-p (1.0 Vp-p for sync on G), 75 ohms; B: 0.7 Vp-p, 75 ohms; HD/VD, SYNC: high impedance, TTL (positive/negative) Y: 1.0 Vp-p (including sync signal); P <sub>B</sub> (C <sub>B</sub> ), P <sub>R</sub> (C <sub>R</sub> ): 0.7 Vp-p, 75 ohms
	AUDIO IN	M3 (L, R) × 1, 0.5 Vrms, input impedance: 22 kilohms or more M3 (L, R) × 1, 0.5 Vrms, input impedance: 22 kilohms or more PIN Jack (L, R) × 2, 0.5 Vrms, input impedance: 22 kilohms or more
	VARIABLE AUDIO OUT	M3 (L, R) × 1 (monitor out: 0–2.0 Vrms, variable)
	SERIAL IN	D-sub 9-pin (female) × 1, for external control (RS-232C compliant)
	REMOTE 1 IN	M3 jack × 1 for wired remote control
	REMOTE 2 IN	D-sub 9-pin (female) × 1, for external control (parallel)
	LAN	RJ-45 × 1 for network and 10Base-T, 100Base-TX, compliant with PLink™ (class 1), Deep Color, compatible with HDCP, 480i(525i) <sup>*3</sup> , 576i(625i) <sup>*3</sup> , 480p(525p), 576p(625p), 720(750)/60p, 720(750)50p, 1080(1125)/60i, 1080(1125)/50i, 1080(1125)/25p, 1080(1125)/24p, 1080(1125)/24sF, 1080(1125)/30p, 1080(1125)/60p, 1080(1125)/50p VGA (640 × 400)–WUXGA <sup>*4</sup> (1,920 × 1,200), dot clock: 25 MHz–162 MHz <b>NOTE: Compatible with non-interlaced signals only.</b>

LCD Projectors

Power cord length		3.0 m (9 ft 10 in)
Cabinet materials		Molded plastic
Dimensions (W × H × D)	PT-EX510	530 × 177* <sup>5</sup> × 445 mm (20-7/8 × 6-31/32* <sup>5</sup> × 17-17/32 inches) (with supplied lens)
	PT-EX510L	530 × 177* <sup>5</sup> × 385 mm (20-7/8 × 6-31/32* <sup>5</sup> × 15-5/32 inches) (without lens)
Weight* <sup>6</sup>	PT-EX510	Approx. 10.6 kg (23.4 lbs) (with supplied lens)
	PT-EX510L	Approx. 9.8 kg (21.6 lbs) (without lens)
Operation noise* <sup>2</sup>		35 dB (LAMP POWER: NORMAL), 29 dB (LAMP POWER: ECO)
Operating temperature		0–45 °C* <sup>7</sup> (32–113 °F)* <sup>7</sup>
Operating humidity		10%–80% (no condensation)

**Remote control unit**

Power supply		3 V DC (R03/LR03/AAA type battery × 2)
Operation range* <sup>8</sup>		Approx. 30 m (98 ft 5 in) when operated from directly in front of the signal receptor
Dimensions (W × H × D)		48 × 145 × 27 mm (1-7/8 × 5-23/32 × 1-1/16 inches)
Weight		Approx. 102 g (3.6 oz) (including batteries)

**Supplied accessories**

- Power cord (including power cord holder) (× 1)
- Wireless/wired remote control unit (× 1)
- Batteries for remote control (AAA/R03/LR03 type × 2)
- Software CD-ROM (Logo Transfer Software, Multi Projector Monitoring & Control Software) (× 1)

**Optional accessories**

Zoom lens (1.3–1.7:1)	ET-ELW20
Zoom lens (2.8–4.6:1)	ET-ELT20
Zoom lens (4.6–7.2:1)	ET-ELT21
Fixed-focus lens (0.8:1)	ET-ELW21
Ceiling mount bracket	ET-PKD120H (for high ceilings) ET-PKD120S (for low ceilings)
Bracket assembly	ET-PKE300B (for ET-PKD120H/PKD120S) ET-PKE200B* <sup>9</sup>
Replacement lamp unit	ET-LAE300
Replacement filter unit	ET-RFE300

Weights and dimensions shown are approximate. Specifications and appearance are subject to change without notice.

- \*1 When the standby mode is set to eco, network functions such as power on over the LAN network will not operate, and the serial output terminal cannot be used. Also, only certain commands can be received for external control using the serial terminal. Only Taiwan model, 0.15 W.
- \*2 Measurement, measuring conditions, and method of notation all comply with ISO 21118 international standards.
- \*3 Only compatible with dot clock frequency of 27 MHz (pixel repetition signal)
- \*4 WUXGA resolution is supported only when the signals are compliant with VESA CVT-RB (Coordinated Video Timing-Reduced Blanking).
- \*5 With legs at shortest position.
- \*6 Average value. May differ depending on models.
- \*7 The operating temperature range is 0 °C to 40 °C (32 °F to 104 °F) when used at altitudes between 1,400 m and 2,700 m (4,593 ft to 8,858 ft) above sea level. When operating temperature exceeds 40 °C (35 °C at high altitude), lamp power may automatically switch to ECO in order to protect the projector.
- \*8 Operation range differs depending on environments.
- \*9 If the ceiling mount bracket of the ET-PKE200H or ET-PKE200S has already been installed, use the projector attachment for the ET-PKE200B.

**Dimensions**

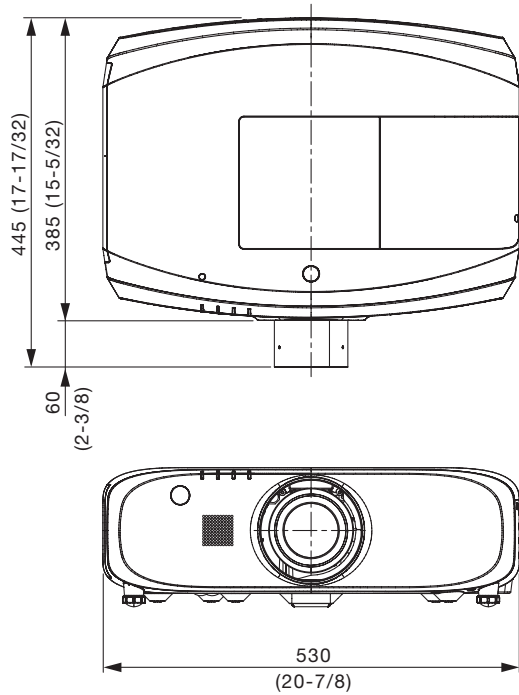

unit : mm (inch)  
 NOTE: This illustration is not drawn to scale.  
 The illustration shows the PT-EX510.

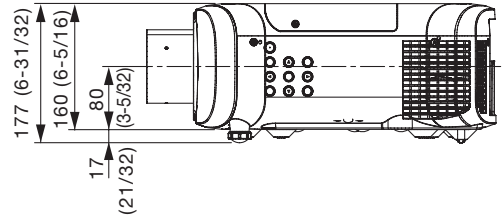

**Terminals**

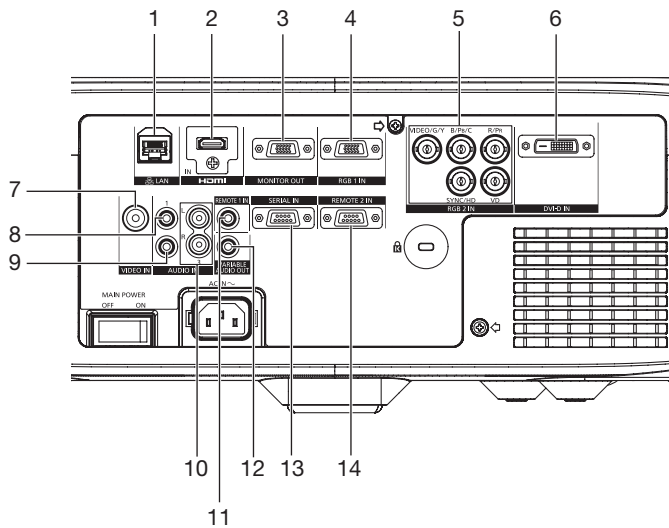

- 1 LAN
- 2 HDMI input
- 3 MONITOR output
- 4 RGB1 input
- 5 RGB2 input
- 6 DVI-D input
- 7 Video input
- 8 Audio 1 input
- 9 Audio 2 input
- 10 Audio 3 input
- 11 Remote 1 input
- 12 Audio output
- 13 Serial input
- 14 Remote 2 input

Standard setting-up position

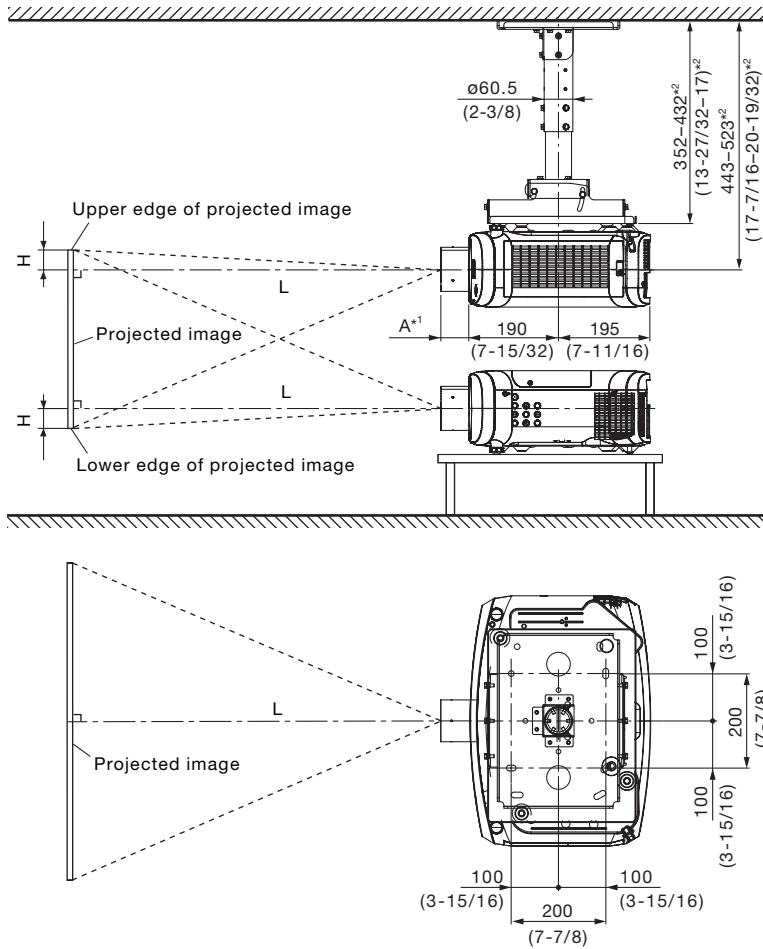

\*1 When the lens protrudes to the maximum.  
 A: 79.5 mm (3-1/8 in) with the ET-ELW20  
 60 mm (2-3/8 in) with the supplied lens  
 84 mm (3-5/16 in) with the ET-ELT20  
 80 mm (3-5/32 in) with the ET-ELT21  
 50 mm (1-31/32 in) with the ET-ELW21

\*2 Adjustable in 40 mm (1-9/16 in) steps.

NOTE:

Illustrations show the projector installed using optional ceiling mount bracket ET-PKD120H and bracket assembly ET-PKE300B.

This illustration is not drawn to scale.

unit : mm (inch)

**Caution:**

- All construction work should be done by a qualified technician.
- When mounting to the ceiling, use the special mounting bracket. To prevent the projector from swaying or dropping, attach the wire between the mounting bracket and the ceiling.

Projection distance for 4:3 aspect ratio screen

Unit: meters

Screen size (diagonal)		Distance to screen (L)									Height from the edge of screen to center of lens (H)	
		Zoom								Fixed-focus	Zoom lenses	Fixed- focus lens
		ET-ELW20 Zoom lens		<i>Supplied lens</i>		ET-ELT20 Zoom lens		ET-ELT21 Zoom lens		ET-ELW21 Fixed-focus lens		
[m]	[in]	min.	max.	min.	max.	min.	max.	min.	max.			
1.02/	40	0.97	1.35	<b>1.30</b>	<b>2.26</b>	2.19	3.65	3.56	5.78	0.60	0.00 – 0.61	0.30
1.27/	50	1.23	1.70	<b>1.64</b>	<b>2.83</b>	2.77	4.59	4.50	7.27	0.77	0.00 – 0.76	0.38
1.52/	60	1.49	2.05	<b>1.98</b>	<b>3.41</b>	3.34	5.53	5.44	8.77	0.93	0.00 – 0.91	0.46
1.78/	70	1.74	2.40	<b>2.32</b>	<b>3.98</b>	3.92	6.47	6.38	10.27	1.10	0.00 – 1.07	0.53
2.03/	80	2.00	2.75	<b>2.66</b>	<b>4.56</b>	4.50	7.41	7.32	11.77	1.26	0.00 – 1.22	0.61
2.29/	90	2.26	3.10	<b>3.00</b>	<b>5.14</b>	5.07	8.35	8.27	13.26	1.43	0.00 – 1.37	0.69
2.54/	100	2.51	3.45	<b>3.33</b>	<b>5.71</b>	5.65	9.29	9.21	14.76	1.59	0.00 – 1.52	0.76
3.05/	120	3.03	4.15	<b>4.01</b>	<b>6.86</b>	6.80	11.17	11.09	17.75	1.92	0.00 – 1.83	0.91
3.81/	150	3.80	5.20	<b>5.03</b>	<b>8.59</b>	8.53	14.00	13.92	22.24	2.42	0.00 – 2.29	1.14
5.08/	200	5.08	6.95	<b>6.72</b>	<b>11.47</b>	11.41	18.70	18.63	29.73	3.24	0.00 – 3.05	1.52
6.35/	250	6.37	8.70	<b>8.42</b>	<b>14.35</b>	14.30	23.40	23.34	37.21	4.07	0.00 – 3.81	1.91
7.62/	300	7.65	10.45	<b>10.11</b>	<b>17.23</b>	17.18	28.11	28.05	44.70	4.89	0.00 – 4.57	2.29
8.89/	350	8.94	12.20	<b>11.81</b>	<b>20.11</b>	20.06	32.81	32.76	52.18	5.72	0.00 – 5.33	2.67
10.16/	400	10.22	13.95	<b>13.50</b>	<b>22.99</b>	22.94	37.51	37.47	59.67	6.54	0.00 – 6.10	3.05

Unit: feet

Screen size (diagonal)		Distance to screen (L)									Height from the edge of screen to center of lens (H)	
		Zoom								Fixed-focus	Zoom lenses	Fixed- focus lens
		ET-ELW20 Zoom lens		<i>Supplied lens</i>		ET-ELT20 Zoom lens		ET-ELT21 Zoom lens		ET-ELW21 Fixed-focus lens		
[m]	[in]	min.	max.	min.	max.	min.	max.	min.	max.			
1.02/	40	3.2	4.4	<b>4.3</b>	<b>7.4</b>	7.2	12.0	11.7	19.0	2.0	0.0 – 2.0	1.0
1.27/	50	4.0	5.6	<b>5.4</b>	<b>9.3</b>	9.1	15.1	14.8	23.9	2.5	0.0 – 2.5	1.3
1.52/	60	4.9	6.7	<b>6.5</b>	<b>11.2</b>	11.0	18.1	17.8	28.8	3.1	0.0 – 3.0	1.5
1.78/	70	5.7	7.9	<b>7.6</b>	<b>13.1</b>	12.9	21.2	20.9	33.7	3.6	0.0 – 3.5	1.8
2.03/	80	6.6	9.0	<b>8.7</b>	<b>15.0</b>	14.8	24.3	24.0	38.6	4.1	0.0 – 4.0	2.0
2.29/	90	7.4	10.2	<b>9.8</b>	<b>16.9</b>	16.6	27.4	27.1	43.5	4.7	0.0 – 4.5	2.3
2.54/	100	8.2	11.3	<b>10.9</b>	<b>18.7</b>	18.5	30.5	30.2	48.4	5.2	0.0 – 5.0	2.5
3.05/	120	9.9	13.6	<b>13.2</b>	<b>22.5</b>	22.3	36.7	36.4	58.2	6.3	0.0 – 6.0	3.0
3.81/	150	12.5	17.0	<b>16.5</b>	<b>28.2</b>	28.0	45.9	45.7	73.0	7.9	0.0 – 7.5	3.8
5.08/	200	16.7	22.8	<b>22.1</b>	<b>37.6</b>	37.4	61.3	61.1	97.5	10.6	0.0 – 10.0	5.0
6.35/	250	20.9	28.5	<b>27.6</b>	<b>47.1</b>	46.9	76.8	76.6	122.1	13.3	0.0 – 12.5	6.3
7.62/	300	25.1	34.3	<b>33.2</b>	<b>56.5</b>	56.4	92.2	92.0	146.7	16.0	0.0 – 15.0	7.5
8.89/	350	29.3	40.0	<b>38.7</b>	<b>66.0</b>	65.8	107.6	107.5	171.2	18.8	0.0 – 17.5	8.8
10.16/	400	33.5	45.8	<b>44.3</b>	<b>75.4</b>	75.3	123.1	122.9	195.8	21.5	0.0 – 20.0	10.0

- The value for L (distance to screen) varies slightly within ±5% depending on the zoom lens characteristics.
- The zoom lens characteristics may cause slight image distortion.
- When vertical keystone correction is used, the image is corrected in the direction that reduces its projected size.
- The brightness varies depending on the zoom setting.

Note: When the fixed-focus lens ET-ELW21 is mounted, the optical lens shift function cannot be used.

**Calculation of the projection distance**

For a screen size different from the above, use the equation below to calculate the projection distance.

**Aspect ratio 4:3**

ET-ELW20	minimum	$L (m) = (\text{diagonal screen size in inches}) \times 0.02570 - 0.05580$
	maximum	$L (m) = (\text{diagonal screen size in inches}) \times 0.03500 - 0.05400$

<i>Supplied lens</i>	<i>minimum</i>	<i><math>L (m) = (\text{diagonal screen size in inches}) \times 0.03390 - 0.05530</math></i>
	<i>maximum</i>	<i><math>L (m) = (\text{diagonal screen size in inches}) \times 0.05760 - 0.04800</math></i>

ET-ELT20	minimum	$L (m) = (\text{diagonal screen size in inches}) \times 0.05764 - 0.11420$
	maximum	$L (m) = (\text{diagonal screen size in inches}) \times 0.09406 - 0.11290$

ET-ELT21	minimum	$L (m) = (\text{diagonal screen size in inches}) \times 0.09421 - 0.21320$
	maximum	$L (m) = (\text{diagonal screen size in inches}) \times 0.14970 - 0.21090$

ET-ELW21	(fixed focus)	$L (m) = (\text{diagonal screen size in inches}) \times 0.16500 - 0.058500$
----------	---------------	---

- Distances calculated with the above equations will include a slight error.



**Shift range**

Optical axis shift function allows to shift the position of a projected image as shown below.

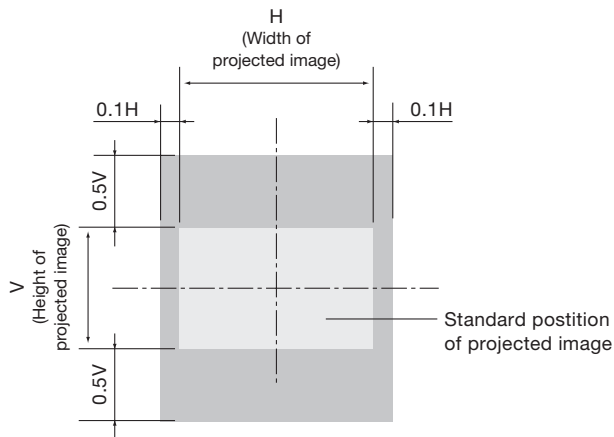

- The ET-ELW21 is a fixed short-focus lens. Therefore, the lens shift function provided in the main unit cannot be used.

**Installable angle**

Install the projector at an angle within the range shown below.

• **Vertical direction**

The projector may be installed at a vertical angle of  $\pm 360^\circ$ .

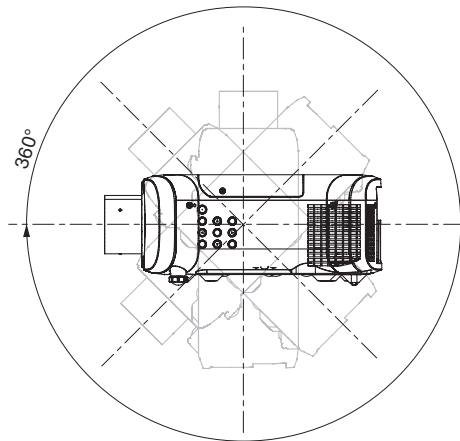

• **Horizontal direction**

The projector may be installed at a horizontal angle of  $\pm 15^\circ$ .

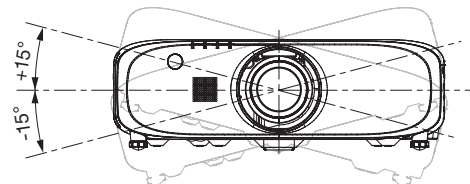

**List of compatible signals**

The signals that can be input to this projector are shown in the table below. Horizontal scanning frequencies of 15 kHz to 100 kHz, vertical scanning frequencies of 24 Hz to 120 Hz, and a dot clock of 162 MHz maximum can be input.

**NOTE:** The native resolution of this projector is 1,024 × 768 pixels. If the display resolution of the input signal is different from the native resolution, image compression or expansion will be used to convert the input signal to a level within the native resolution.

Display mode	Display resolution (dots)*1	Scanning frequency		Dot clock frequency (MHz)	Format
		H (kHz)	V (kHz)		
NTSC/NTSC4.43/PAL-M/PAL60	720 × 480i	15.7	59.9	–	VIDEO/S-VIDEO
PAL/PAL-N/SECAM	720 × 576i	15.6	50.0	–	
525i (480i)	640 × 480i	15.7	59.9	13.5	YCbCr/RGB
625i (576i)	768 × 576i	15.6	50.0	13.5	
525i (480i)	720(1440) × 480i*2	15.7	59.9	27.0	HDMI/DVI-D
625i (576i)	720(1440) × 576i*2	15.6	50.0	27.0	
525p (480p)	720 × 480i	31.5	60.0	27.0	HDMI/DVI-D/ YPbPr/RGB
625p (576p)	720 × 576i	31.3	50.0	27.0	
750 (720)/60p	1280 × 720	45.0	60.0	74.3	
750 (720)/50p		37.5	50.0	74.3	
1125 (1080)/60i*3	1920 × 1080i	33.8	60.0	74.3	
1125 (1080)/50i		28.1	50.0	74.3	
1125 (1080)/25p	1920 × 1080	28.1	25.0	74.3	
1125 (1080)/24p		27.0	24.0	74.3	
1125 (1080)/24sF		27.0	48.0	74.3	
1125 (1080)/30p		33.8	30.0	74.3	
1125 (1080)/60p		67.5	60.0	148.5	
1125 (1080)/50p		56.3	50.0	148.5	
VESA400	640 × 400	37.9	85.1	31.5	HDMI/DVI-D/RGB
VGA	640 × 400	31.5	70.1	25.2	
	640 × 480	31.5	59.9	25.2	
		35.0	66.7	30.2	
		37.5	75.0	31.5	
		37.9	72.8	31.5	
		43.3	85.0	36.0	
SVGA	800 × 600	35.2	56.3	36.0	
		37.9	60.3	40.0	
		46.9	75.0	49.5	
		48.1	72.2	50.0	
		53.7	85.1	56.3	
MAC16	832 × 624	49.7	74.6	57.3	
XGA	1024 × 768	39.6	50.0	51.9	
		48.4	60.0	65.0	
		56.5	70.1	75.0	
		60.0	75.0	78.8	
		65.5	81.6	86.0	
		68.7	85.0	94.5	
		81.4	100.0	113.3	
		98.8	120.0	139.1	
MXGA	1152 × 864	53.7	60.0	81.6	
		64.0	70.0	94.2	
		67.5	74.9	108.0	
		77.1	85.0	119.7	
MAC21	1152 × 870	68.7	75.1	100.0	

\*1 The “i” appearing after the resolution indicates an interlaced signal.  
 \*2 Only compatible with dot clock frequency of 27 MHz (pixel repetition signal)  
 \*3 Compliant with VESA CVT-RB (Coordinated Video Timing-Reduced Blanking).

Display mode	Display resolution (dots)*1	Scanning frequency		Dot clock frequency (MHz)	Format
		H (kHz)	V (kHz)		
1280 × 720	1280 × 720	37.1	49.8	60.5	HDMI/DVI-D/RGB
		44.8	59.9	74.5	
		76.3	100.0	131.8	
		92.6	120.0	161.6	
1280 × 768	1280 × 768	39.6	49.9	65.3	
	1280 × 768*2	47.4	60.0	68.3	
	1280 × 768	47.8	59.9	79.5	
		60.3	74.9	102.3	
		68.6	84.8	117.5	
1280 × 800	1280 × 800	41.3	50.0	68.6	
	1280 × 800*2	49.3	59.9	71.0	
	1280 × 800	49.7	59.8	83.5	
		62.8	74.9	106.5	
		71.6	84.9	122.5	
MSXGA	1280 × 960	60.0	60.0	108.0	
SXGA	1280 × 1024	52.4	50.0	88.0	
		64.0	60.0	108.0	
		72.3	66.3	125.0	
		78.2	72.0	135.1	
		80.0	75.0	135.0	
		91.1	85.0	157.5	
1366×768	1366 × 768	39.6	49.9	69.0	
		47.7	59.8	85.5	
SXGA+	1400 × 1050	54.1	50.0	99.9	
		64.0	60.0	108.2	
		65.2	60.0	122.6	
		65.3	60.0	121.8	
		78.8	72.0	149.3	
		82.2	75.0	155.9	
WXGA+	1440 × 900	55.9	59.9	106.5	
1600×900		46.3	50.0	97.0	
		55.9	60.0	119.0	
UXGA60	1600 × 1200	75.0	60.0	162.0	
WSXGA+	1680 × 1050	54.1	50.0	119.5	
		65.3	60.0	146.3	
1920×1080	1920 × 1080	55.6	49.9	141.5	
	1920 × 1080*2	66.6	59.9	138.5	
	1920 × 1080*3	67.2	60.0	173.0	
		61.8	49.9	158.3	RGB
WUXGA	1920 × 1200	61.8	49.9	158.3	HDMI/DVI-D/RGB
	1920 × 1200*2	74.0	60.0	154.0	
	1920 × 1080*3	74.6	59.9	193.3	
					RGB

\*1 The "i" appearing after the resolution indicates an interlaced signal.  
 \*2 Compliant with VESA CVT-RB (Coordinated Video Timing-Reduced Blanking).  
 \*3 The image processing circuit reduces the number of pixels to display images.

**Serial connector**

The serial connector complies with RS-232C. To control the projector from a personal computer, commands must be input through communication software, based on the format and satisfying the communication conditions shown below.

**Pin assignments and signal names**

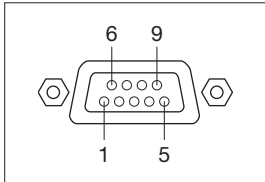

D-sub 9-pin (female) Serial input

No.	Signal name	Description	No.	Signal name	Description
1	-	NC	6	-	NC
2	TXD	Transmitted data	7	CTS	Connected internally
3	RXD	Received data	8	RTS	Connected internally
4	-	Connected internally	9	-	NC
5	GND	Ground			

**Communication conditions (factory setting)**

Signal level	RS-232C-compliant
Synchronization method	Start-stop synchronization
Baud rate	9,600 bps
Parity	None
Character length	8 bits
Stop bit	1 bit
X parameter	None
S parameter	None

**Basic format**

Transmission from the computer begins with STX, then the ID, command, parameter, and ETX are sent in this order. Add parameters according to the details of control.

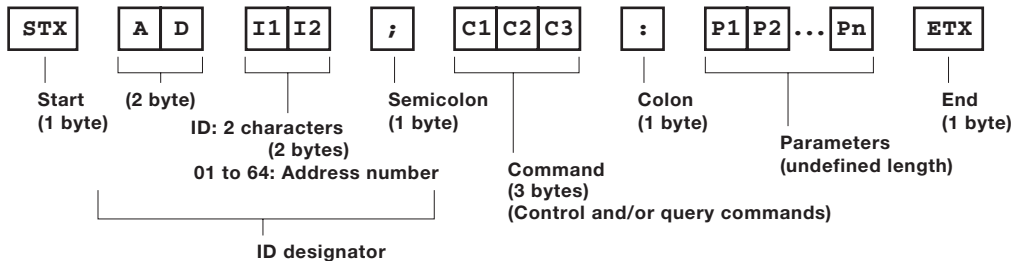

**CAUTION**

- It may not be possible to send or receive commands for about 10 to 60 seconds when the lamp is first turned on. If this occurs, wait for 60 seconds, then try sending or receiving again.
- When sending multiple commands, be sure to wait for at least 0.5 second after receiving a response from the projector before sending the next command.
- Additional time is sometimes required for response due to processing inside the projector. Set the time-out period for command response to 10 seconds or more.
- When using two or more units, set different IDs for each unit.

**Cable specifications**

Projector		PC (DTE)	
1	NC	NC	1
2			2
3			3
4	NC	NC	4
5			5
6	NC	NC	6
7			7
8			8
9	NC	NC	9

**Control commands**

Command : Parameter	Function		Callback	
<b>PON</b>	Standby power	On	<b>PON</b>	
<b>POF</b>		Off	<b>POF</b>	
<b>OSH:0</b>	Shutter	Off	<b>OSH:0</b>	
<b>OSH:1</b>		On	<b>OSH:1</b>	
<b>IIS:HD1</b>	Input selection	HDMI	<b>IIS:HD1</b>	
<b>IIS:DVI</b>		DVI-D	<b>IIS:DVI</b>	
<b>IIS:RG1</b>		RGB1	<b>IIS:RG1</b>	
<b>IIS:RG2</b>		RGB2	<b>IIS:RG2</b>	
<b>IIS:VID</b>		Video	<b>IIS:VID</b>	
<b>VXX:RYC2=+00000</b>	RGB2 INPUT SETTING	RGB/YPbPr	<b>VXX:RYC2=+00000</b>	
<b>VXX:RYC2=+00001</b>		S-Video	<b>VXX:RYC2=+00001</b>	
<b>VXX:RYC2=+00002</b>		Video	<b>VXX:RYC2=+00002</b>	
<b>VXX:LPWI1=+00030</b>	Lamp power	Auto	<b>VXX:LPWI1=+00030</b>	
<b>VXX:LPWI1=+00001</b>		Normal	<b>VXX:LPWI1=+00001</b>	
<b>VXX:LPWI1=+00000</b>		Eco	<b>VXX:LPWI1=+00000</b>	
<b>OAS</b>	Auto setup		<b>OAS</b>	
<b>VSE:0</b>	Aspect	Normal/Auto/VID Auto	<b>VSE:0</b>	
<b>VSE:1</b>		4:3	<b>VSE:1</b>	
<b>VSE:2</b>		Wide	<b>VSE:2</b>	
<b>VSE:5</b>		Real	<b>VSE:5</b>	
<b>VSE:6</b>		Full	<b>VSE:6</b>	
<b>VSE:9</b>		H-fits	<b>VSE:9</b>	
<b>VSE:10</b>		V-fits	<b>VSE:10</b>	
<b>VPM:NAT</b>		Picture	Natural	<b>VPM:NAT</b>
<b>VPM:STD</b>			Standard	<b>VPM:STD</b>
<b>VPM:DYN</b>			Dynamic	<b>VPM:DYN</b>
<b>VPM:CIN</b>	Cinema		<b>VPM:CIN</b>	
<b>VPM:DIC</b>		DICOM Simulation	<b>VPM:DIC</b>	

\* Do not send PON, POF or OSH commands continuously in a short period of time. Doing so may burst the lamp or shorten the lamp replacement cycle.

\* When a command that cannot be executed during standby mode is sent, the projector will send an ER401 command in reply.

**Status request commands**

Command:Parameter	Function	Callback	Description
<b>QPW</b>	Main power status	<b>000</b>	Off
		<b>001</b>	On
<b>QSH</b>	Shutter function status	<b>0</b>	Off
		<b>1</b>	On
<b>QIN</b>	Input signal status	<b>HD1</b>	HDMI
		<b>DVI</b>	DVI-D
		<b>RG1</b>	RGB1
		<b>RG2</b>	RGB2
		<b>VID</b>	Video
<b>QVX:LPWI1</b>	Lamp power mode status	<b>VXX:LPWI1=+00030</b>	Auto
		<b>VXX:LPWI1=+00001</b>	Normal
		<b>VXX:LPWI1=+00000</b>	Eco
<b>QSE</b>	Aspect mode status	<b>0</b>	Normal/Auto/VID Auto
		<b>1</b>	4:3
		<b>2</b>	Wide
		<b>5</b>	Real
		<b>6</b>	Full
		<b>9</b>	H fit
		<b>10</b>	V fit
<b>QPM</b>	Picture mode status	<b>NAT</b>	Natural mode
		<b>STD</b>	Standard mode
		<b>DYN</b>	Dynamic mode
		<b>CIN</b>	Cinema mode
		<b>DIC</b>	DICOM Simulation.mode
<b>QST</b>	Projector run time	<b>p1p2p3p4p5</b>	00000 – 99999 hours
<b>Q\$L:1</b>	Lamp run time	<b>p1p2p3p4</b>	0000 – 9999 hours
<b>QTM:0</b>	Temperature status	<b>p1p2p3p4/p5p6p7p8*1</b>	Air intake
<b>QTM:1</b>		<b>p1p2p3p4/p5p6p7p8*1</b>	Exhaust

\*1 p1p2p3p4 = Celsius (°C), p5p6p7p8 = Fahrenheit (°F)

**NOTE: If a wrong command is received, the projector will send an ER401 or ER402 command to the computer.**

**Command example**

To set the shutter function on, send the command as shown below.

```

STX   ADZZ ; OSH : 1   ETX
  |         |         |         |         |
  Start   ID Address  Command  Parameter End
Character code 02 ZZ: ID ALL
    
```

**NOTE: When sending commands without parameters, a colon (:) is not necessary.**

**Notes on projector placement and operation**

The projector uses a high-wattage lamp that becomes very hot during operation. Please observe the following precautions.

1. Never place objects on top of the projector.
2. Make sure there is an unobstructed space of 1,000 mm (3 feet 3 inches) or more around the projector's exhaust openings.
3. Do not stack projector units directly on top of one another for the purpose of multiple (stacked) projection. When stacking projector units, be sure to provide the amount of space indicated below between them. These space requirements also apply to installations where only one projector unit is operating at one time and the other unit is used as a backup.
4. Make sure that nothing blocks the projector's air intake and exhaust openings. Also, install the projector so that cool or hot air from other air conditioning equipment does not flow directly toward the projector's air intake or exhaust openings.
5. Do not install the projector in an enclosed space. If it is necessary to install it in an enclosed space, add a separate ventilation system. If ventilation is insufficient, hot air will accumulate at the intake opening. This may cause the projector's protective circuit to interrupt projector operation.
6. If the projector is installed in an enclosed space, ensure that the projector's intake and exhaust openings are not blocked. Take particular care to ensure that hot air from the exhaust openings is not sucked into the intake openings.
7. When installing the projector in any manner other than floor mounting with the adjuster legs, use the four threaded ceiling mount holes (screw diameter: M6, projector interior thread length: 12 mm) to secure the projector.

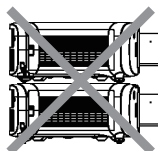
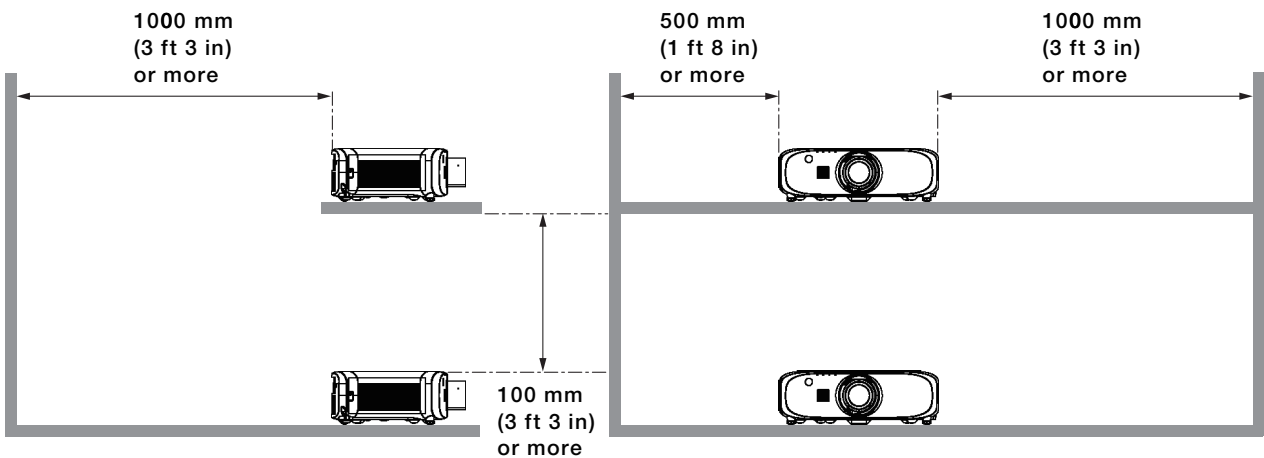

**Do not stack projector units directly on top of one another.**

Direction of air intake and exhaust

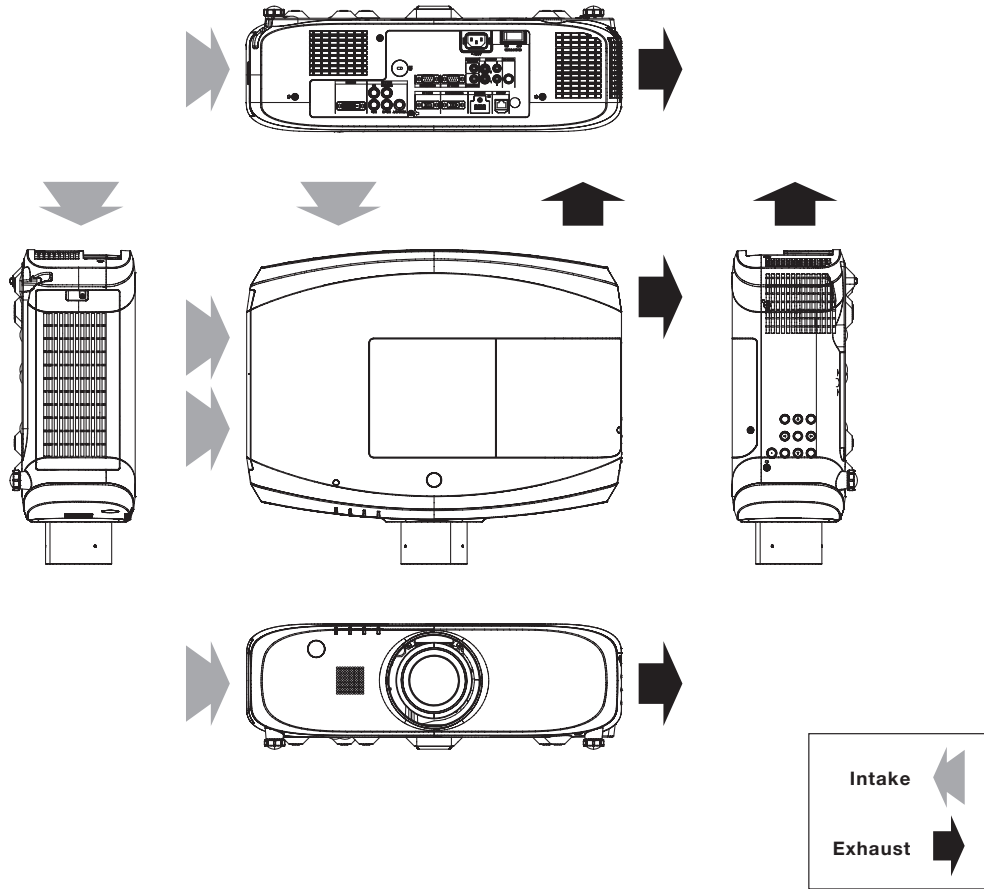

Operating the projector continuously

1. If the projector is to be operated continuously 12 hours or more, lamp replacement cycle duration becomes shorter.
2. The lamp replacement cycle duration becomes shorter if the projector is operated repeatedly for short periods.

Weights and dimensions shown are approximate. Specifications and appearance are subject to change without notice. Product availability differs depending on region and country. This product may be subject to export control regulations.

HDMI, the HDMI logo and High-Definition Multimedia Interface are trademarks or registered trademarks of HDMI Licensing LLC in the United States and other countries. PJLink is a registered trademark, or a trademark application has been filed, in Japan, the United States, and other countries and regions. All other trademarks are the property of their respective trademark owners.